



**noesberger**

**Noesberger Maschinen AG**  
CH - 1717 St. Ursen

Tel. 026 322 22 77  
[www.noesberger.com](http://www.noesberger.com)



**UG, UG A**

Stainless Steel  
Submersible Pumps, 50Hz



## Generelle Informationen

Unterwasserpumpen UG – Serie	Seite	4
Leistungsbereich		5
Programmübersicht		5
Anwendung		6
Typenschlüssel		6
Fördermedium		6
Arbeitsbedingungen		6
Daten zur Kennlinie		6
Druckverluste		6
Teile		7
Werkstoffe		8
Teile		11
Installationszeichnung		12
Pumpen Auslegungsblatt		13

## Technische Informationen

UG1A	Seite	14
UG2A		16
UG3A		18
UG5A		20
UG8A		22
UG14A		24
UG17		26
UG30		31
UG46		36
UG60		41
UG77		46
UG95		51
UG125		56
UG160		61
UG215		66
Druckverluste in Druckleitungen		71
Druckverluste in Plastikleitungen		72
Kabelauswahl		74
Motoren Kabelgrößen		75

## Unterwasserpumpen UG – Serie

**Deutsch** - SPCO Unterwasserpumpen der Baureihe UG und UG A für Brunnen ab 4" (DN 100) und mit Förderströmen bis zu 280 m<sup>3</sup>/h. Alle wesentlichen Teile, wie zum Beispiel Welle, Laufräder und Zwischenkammern sind aus komplett nicht rostenden Stahl AISI 304 (W-Nr. 1.4301) gefertigt. Die Dichtungen sind aus besonders korrosions- und chemikalienbeständigen Werkstoffen und die Lager aus einer Hartmetall / Keramik – Kombination hergestellt.

Die Konstruktion der Pumpen in Chrom-Nickel Stahl ergibt eine leichte Bauweise mit guten Wirkungsgraden. Dadurch können der Stromverbrauch und die Installationskosten auf ein Minimum reduziert werden.

**Français** - Les pompes immergées de l'assortiment UG et UG A pour puits dès 4" (DN100) et avec des courants propulsés jusqu'à 280 m<sup>3</sup>/h. Toutes les pièces principales, comme par exemple axes, roués libres et espaces intermédiaires sont fabriqués spéciaux matériaux anticorrosifs et les produits chimiques et roulements de métaux dur / combinaison céramique. La méthode de construction des pompes en acier chrome – nickel donne une méthode de construction légère de bons degrés de fonctionnement. Par cela la consommation d'électricité et les frais d'installation peuvent être réduits au minimum.

**English** - SPCO submersible pumps UG and UG A for deep wells starting from 4" (DN 100) and with flow up to 280 m<sup>3</sup>/h. All essential parts, such as shaft, impellers and intermediate chambers are made of fully stainless steel AISI 304. The sealings are made of corrosion- and chemical resistant materials and the bearings consist of hard metal / ceramic combination.

The light stainless steel construction allows high efficiency through which the energy consumption is drastically reduced. The cost and time for installation is lower due to the light weight of the stainless steel sheet metal pump construction.

**Italiano** - SPCO – Pompe sommergibili "UG" e "UG A" per pozzi profondi da 4" (DN 100) fino a 12" (DN 250) con portata fino 280mc/h e prevalenza fino a mt 600.

Costruite con le parti essenziali – alberi, giranti, diffusori, camere intermedie – realizzate da lastra lucida di acciaio Inox 304. Anelli di usura sono di materiale resistente alla corrosione ed all'azione di aggressivi chimici. Supporti sono realizzati dalla combinazione di ceramica e metallo duro (carburo di tungsteno).

La costruzione così realizzata con Acciaio Inox leggero risulta più efficiente e consente quindi importanti risparmi di energia e costi di installazione notevolmente ridotti.

# Leistungsbereich

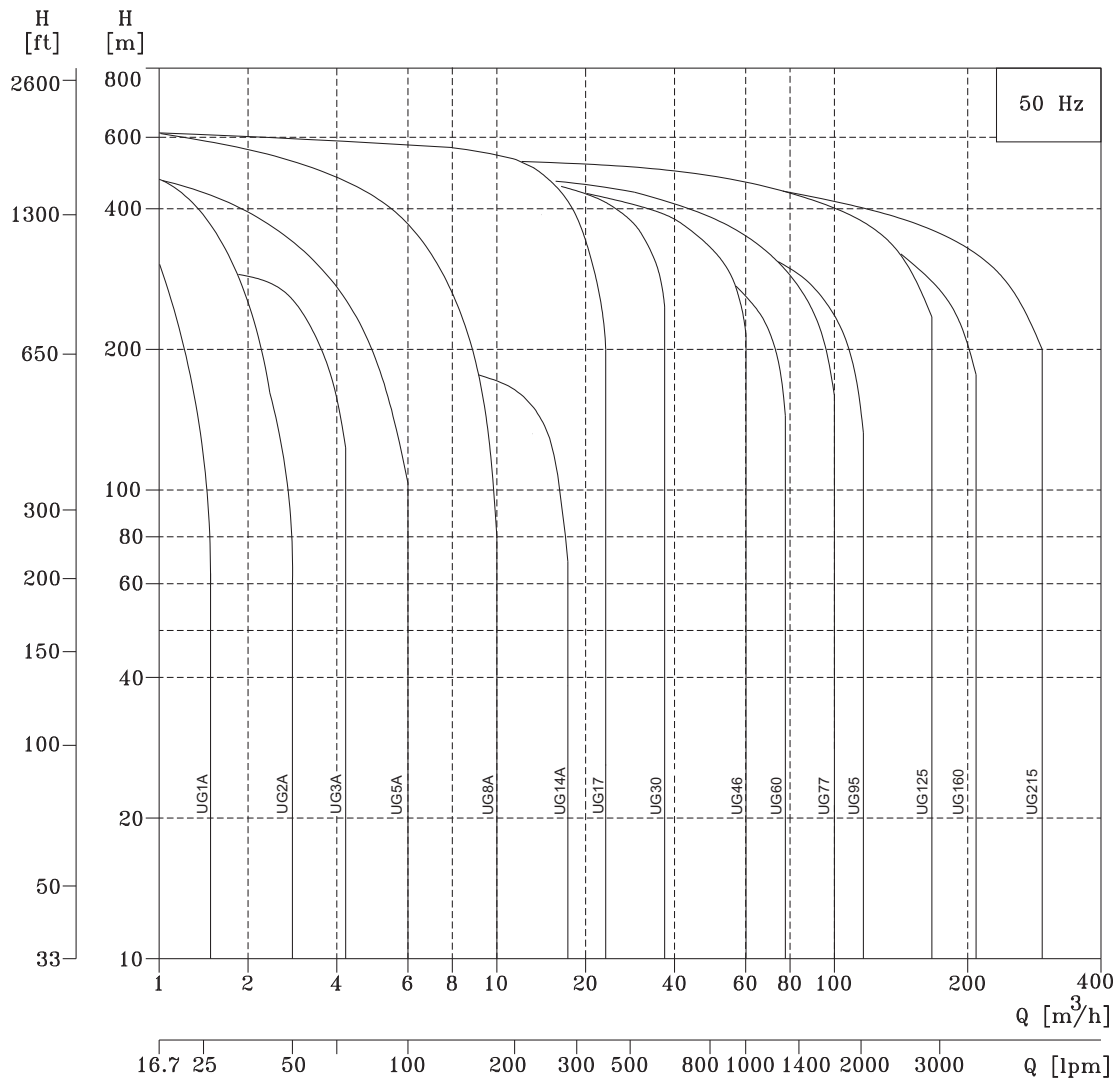

## Programmübersicht Pumpen

Typ	UG1A	UG2A	UG3A	UG5A	UG8A	UG14A	UG17	UG30	UG46	UG60	UG77	UG95	UG125	UG160	UG215
Stahl : 1.43 rostfrei	+	+	+	+	+	+	+	+	+	+	+	+	+	+	+
Anschluss: Rp (Zoll) BSP Gewinde	1 <sup>1/4</sup>	1 <sup>1/4</sup>	1 <sup>1/4</sup>	1 <sup>1/2</sup>	2	2	2 <sup>1/2</sup>	3	3 4	3 4	5	5	6	6	6
NPT Gewinde	1 <sup>1/4</sup>	1 <sup>1/4</sup>	1 <sup>1/4</sup>	1 <sup>1/2</sup>	2	2	3	3	3 4	3 4	5	5	6	6	6
Flansanschluss											5"	5"	6"	6"	6"

## Anwendung

Die Pumpen sind geeignet für folgende Anwendungen:

- zur Förderung von Rohwasser
- für Bewässerungssysteme
- für Bodenentwässerungen
- für Druckerhöhungsanlagen
- für industrielle Anwendungen

## Typenschlüssel

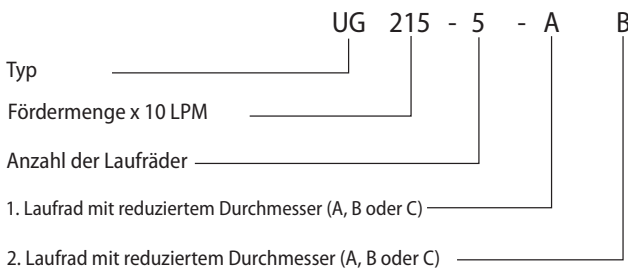

## Fördermedium

Sauber, nicht verstopfendes Medium ohne Feststoffe

Feststoffe mit max. 50 mg pro Liter

## Arbeitsbedingungen

Fördermenge Q: 0.1 - 280 m<sup>3</sup>/h

Förderhöhe H: max. 670m

Max. Installationsdruck: 20 bar (290 PSI)

### Maximale Fördermediums Temperatur:

Motor	Installation		
	Förderstrom Geschwindigkeit am Motor	Vertikal	Horizontal
SPCO 4", 6" & 8"	0.15 m/s	50°C	50°C

Arbeitsdruck: max. 670 m (67 bar)

## Daten zur Kennlinie

- Curve tolerance according to ISO 9906, Annex A

- Toleranz der Kurve nach ISO 9906, Annex A

- Die Kennlinie zeigt sich gemäss folgender Drehzahl des Motors:

- Die ungefähre Drehzahl ist ca:

4" und 6" Motoren: n= 2870 min<sup>-1</sup>

8" bis 12" Motoren: n=2900 min<sup>-1</sup>

- Die Messung wurde gemacht mit Wasser ohne Luft und einer Temperatur von 20°C. Die Kurve unterliegt einer kinetischen Viskosität von 1 mm<sup>2</sup>/5. Wenn das Fördermedium mit einer höheren Dichte als Wasser verwendet wird, müssen entsprechend grössere Motoren eingesetzt werden.

- Die dicke Kennlinie zeigt wo die Pumpe am besten eingesetzt werden sollte.

- Die Kennlinien sind inklusive möglichen Verlusten der Rückschlagklappe.

## Tabelle des Druckverlustes

### UG1A, UG2A, UG3A, UG5A, UG8A, UG14A Kurves

- Q/H : Die Kurven sind inklusive der Armaturen und dem Druckverlust beim Einlass mit der normalen Geschwindigkeit.

- Leistungskennlinien: BP kW / Stufe zeigt die Stromaufnahme pro Stufe.

- Wirkungsgrad Kurve: Die Wirkungsgradkurve zeigt den Wirkungsgrad pro Stufe.

### UG17,UG30,UG46,UG60,UG77,UG95,UG125, UG160, UG215 Kurves

- Q/H : Die Kurven sind inklusive der Armaturen und dem Druckverlust beim Einlass mit der normalen Geschwindigkeit.

- Einsätze der Pumpe ohne Rückschlagklappe vergrössern den Druck bei normaler Anwendung um ca. 0.5 – 1 m.

- NPSHR ist inklusive des Sauggehäuses und zeigt den benötigten Einlassdruck.

- Leistungskurve: Es zeigt die Leistungsaufnahme bei der aktuellen Drehzahl für jede individuelle Pumpengrösse.

- Wirkungsgradkurve: Die Wirkungsgradkurve zeigt den Wirkungsgrad pro Stufe.

# Daten und Vorteile

## Ein grosses Pumpenangebot

Wir offerieren Unterwasserpumpen mit Energie effizienten Betriebspunkten von 0.1 bis 280 m<sup>3</sup>/h. Die Pumpenpalette besteht aus vielen verschiedenen Grössen. Jeder Pumpentyp ist erhältlich mit der entsprechenden Anzahl Stufen um den Betriebspunkt optimal abzudecken.

## Hoch effiziente Pumpen

Der Wirkungsgrad der Pumpen wird oft vernachlässigt im Vergleich mit dem Preis der Pumpe und dem Motor. Dabei steht fest, dass effiziente Unterwasserpumpen schon nach kurzer Zeit den Mehrpreis durch weniger Stromverbrauch dem Benutzer zurückgewinnt.

## Beispiel:

Wenn man 125 m<sup>3</sup>/h bei 200 m über eine Zeit von 10 Jahren laufen lässt, kann man CHF 55'000 einsparen weil die Pumpe einen 10% höheren Wirkungsgrad hat und einem Strompreis von 10 Rappen pro kW/h.

## Anwendungen

Wir offerieren ein grosses Sortiment an Pumpen und Motoren. Diese sind aus komplett rostfreiem Stahl 1.4301. Das sorgt für eine gute Standhaftigkeit gegen Abnutzung und reduziert die Gefahr der Korrosion wenn normales, kaltes Wasser mit wenig Chlor gefördert wird.

## Geringe Installationskosten

Die rostfreie Ausführung der Pumpe hat weniger Gewicht als anderer Werkstoff. Das erleichtert die Handhabung der Pumpe und resultiert in geringeren Installationskosten sowie kürzere Servicezeiten. Gleichzeitig sind die Pumpen wie neu nach der Revision durch die rostfreie Ausführung der Pumpe.

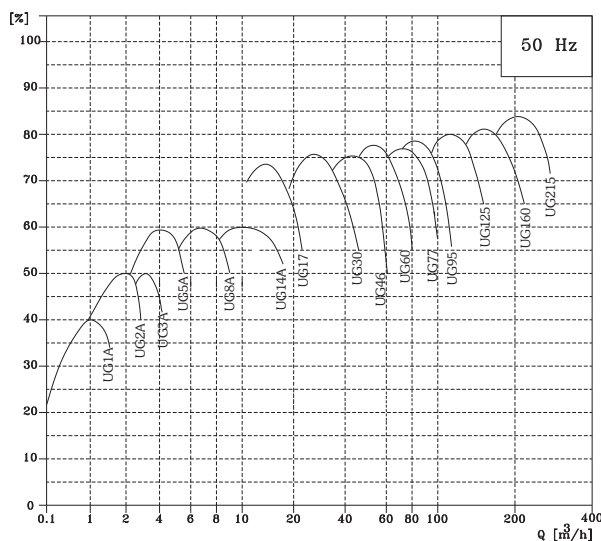

Überblick Pumpenwirkungsgrade.

# Werkstoffe 4" Pumpe

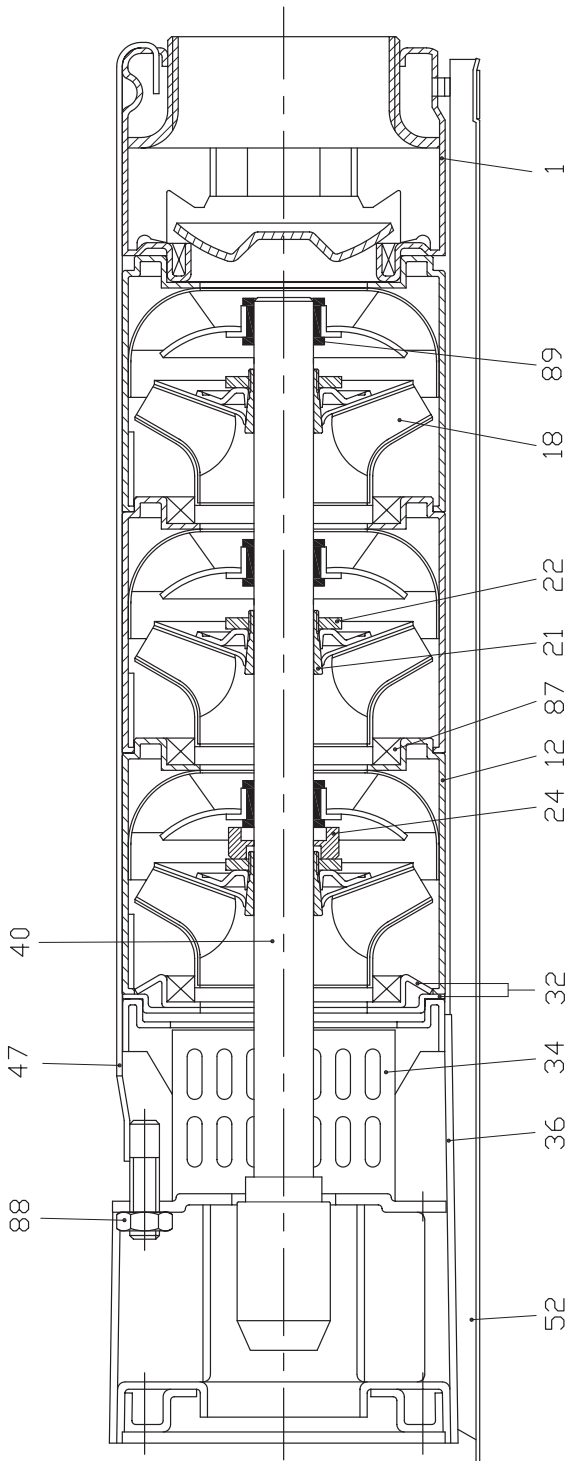

Unterwasserpumpe UG 14

Pos.	Benennung	Werkstoff	Ausführung
01	Abgangstutzen	rostfreier Stahl	304
12	Zwischenkammer	rostfreier Stahl	304
18	Laufblad	rostfreier Stahl	304
21	Stopring	rostfreier Stahl	304
22	Stopring Mutter	rostfreier Stahl	304
24	Stopring	Karbon – Grafit	
32	Gewinding	rostfreier Stahl	304
34	Sieb	rostfreier Stahl	304
36	Einlaufteil	rostfreier Stahl	304
40	Pumpenwelle	rostfreier Stahl	431
37	Kupplung	rostfreier Stahl	304
47	Spannband	rostfreier Stahl	304
52	Kabelschutz	rostfreier Stahl	304
87	Spaltring	SS304+NBR	
88	Mutter	rostfreier Stahl	304
89	Lager	NBR	



# Werkstoffe 6" Pumpe

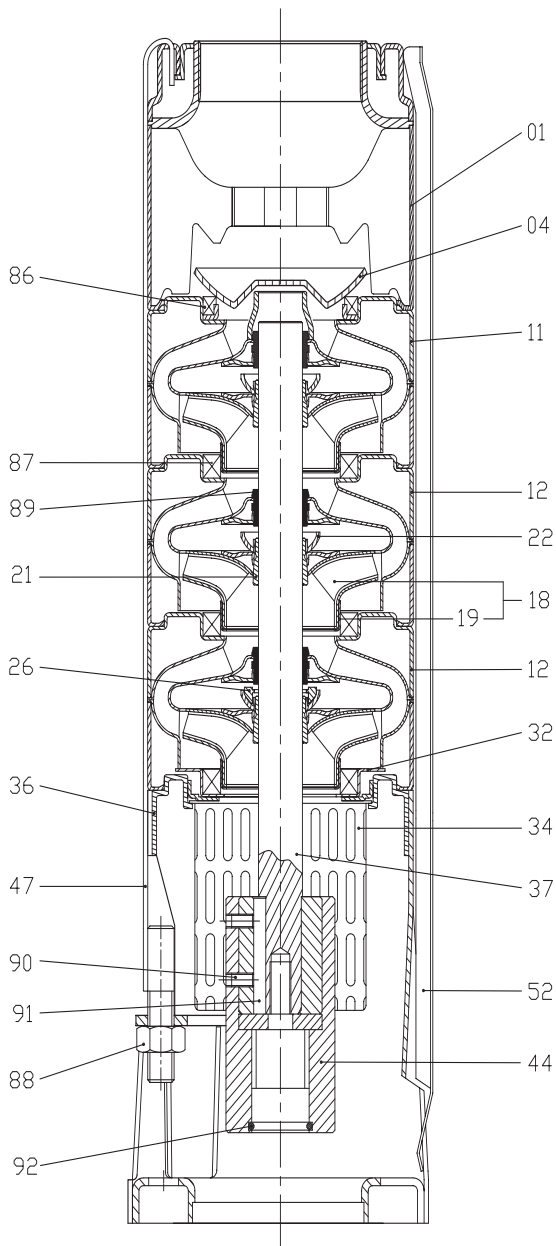

## Unterwasserpumpe UG-17

Pos.	Benennung	Werkstoff	Ausführung
01	Abgangstutzen	rostfreier Stahl	304
04	Ventilteller	rostfreier Stahl	304
11	oberes Ventilgehäuse	rostfreier Stahl	304
12	Zwischenkammer	rostfreier Stahl	304
18	Lauftrad	rostfreier Stahl	304
19	Klembuchse	rostfreier Stahl	304
21	Stopring	rostfreier Stahl	304
22	Stopring Mutter	rostfreier Stahl	304
26	Spaltring	Karbon – Grafit	
32	Gewinding	rostfreier Stahl	304
34	Sieb	rostfreier Stahl	304
36	Einlaufteil	rostfreier Stahl	304
37	Pumpenwelle	rostfreier Stahl	431
44	Kupplung	rostfreier Stahl	304
47	Spannband	rostfreier Stahl	304
52	Kabelschutz	rostfreier Stahl	304
86	Ventilsitz	SS304+NBR	
87	Spaltring	SS304+NBR	
88	Mutter	rostfreier Stahl	304
89	Lager	NBR	
90	Schraube	rostfreier Stahl	304
91	Keil	rostfreier Stahl	304
92	O-Ring	NBR	

# Werkstoffe 8" Pumpe

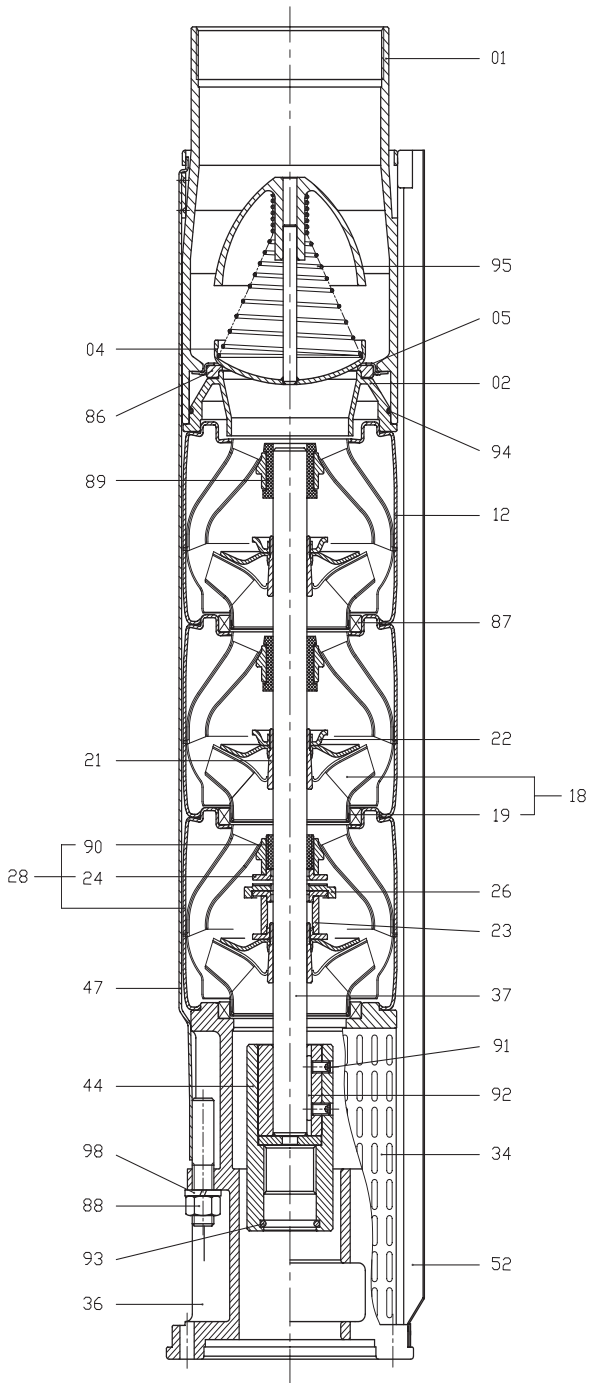

Unterwasserpumpe UG-95

Pos.	Components	Material	Standard
01	Abgangsstutzen	rostfreier Stahl	304
02	Unterer Ventilsitz	rostfreier Stahl	304
04	Ventilteller	rostfreier Stahl	304
05	Ventilsitz	rostfreier Stahl	304
12	Zwischenkammer	rostfreier Stahl	304
18	Laufgrad	rostfreier Stahl	304
19	Klembuchse	rostfreier Stahl	304
21	Stopring	rostfreier Stahl	304
22	Stopring Mutter	rostfreier Stahl	304
23	Mutter Stopring	rostfreier Stahl	304
24	Stopring	rostfreier Stahl	304
26	Spaltring	Karbon – Grafit	
28	Untere Zwischenkammer	rostfreier Stahl	304
34	Sieb	rostfreier Stahl	304
36	Einlaufteil	rostfreier Stahl	304
37	Pumpenwelle	rostfreier Stahl	431
44	Kupplung	rostfreier Stahl	304
47	Spannband	rostfreier Stahl	304
52	Kabelschutz	rostfreier Stahl	304
86	Ventilsitz	NBR	
87	Gewinding	SS304+NBR	
88	Mutter	rostfreier Stahl	304
89	Lager	NBR	
90	Lager	NBR+SS304	
91	Schraube	rostfreier Stahl	304
92	Keil	rostfreier Stahl	304
93	O-ring	NBR	
94	O-ring	NBR	
95	Feder	rostfreier Stahl	304
98	Federring	rostfreier Stahl	304

# Teile

## Lager mit Sandkanälen

Alle Lager sind mit Wasser geschmiert und haben eine spezielle Form. Dadurch kann Sand und Sandteilen die Pumpe zusammen mit dem geförderten Wasser verlassen.

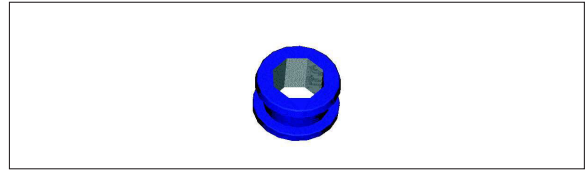

## Einlaufsieb

Das Sieb verhindert das Eindringen von grösseren Feststoffen in die Pumpe.

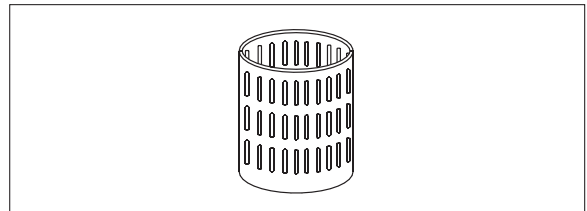

## Rückschlagklappe

Alle Pumpen sind mit einer zuverlässigen Rückschlagklappe ausgestattet. Diese befindet sich im oberen Abgangsstück der Pumpe und verhindert das Zurückfliessen des Wassers wenn die Pumpe abgestellt wird.

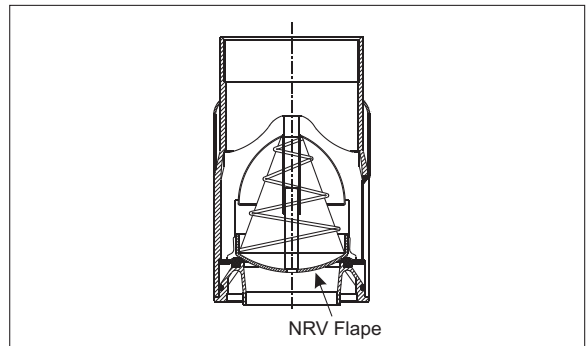

## Stopring

Der Stopring verhindert Schaden an der Pumpe während des Transportes oder wenn bei dem Anlaufen der Pumpe wenn starke Druckschläge auf die Pumpe einwirken. Der Stopring welcher wie ein Lager aussieht, verhindert axiale Verschiebungen der Pumpenwelle.

Beispiel: UG 125

Der stationäre Teil des Stopring (A) ist gesichert in der Zwischenkammer.

Der rotierende Teil (B) ist eingebettet im Stopring (C).

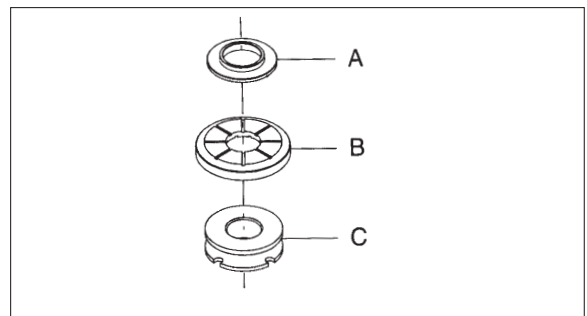

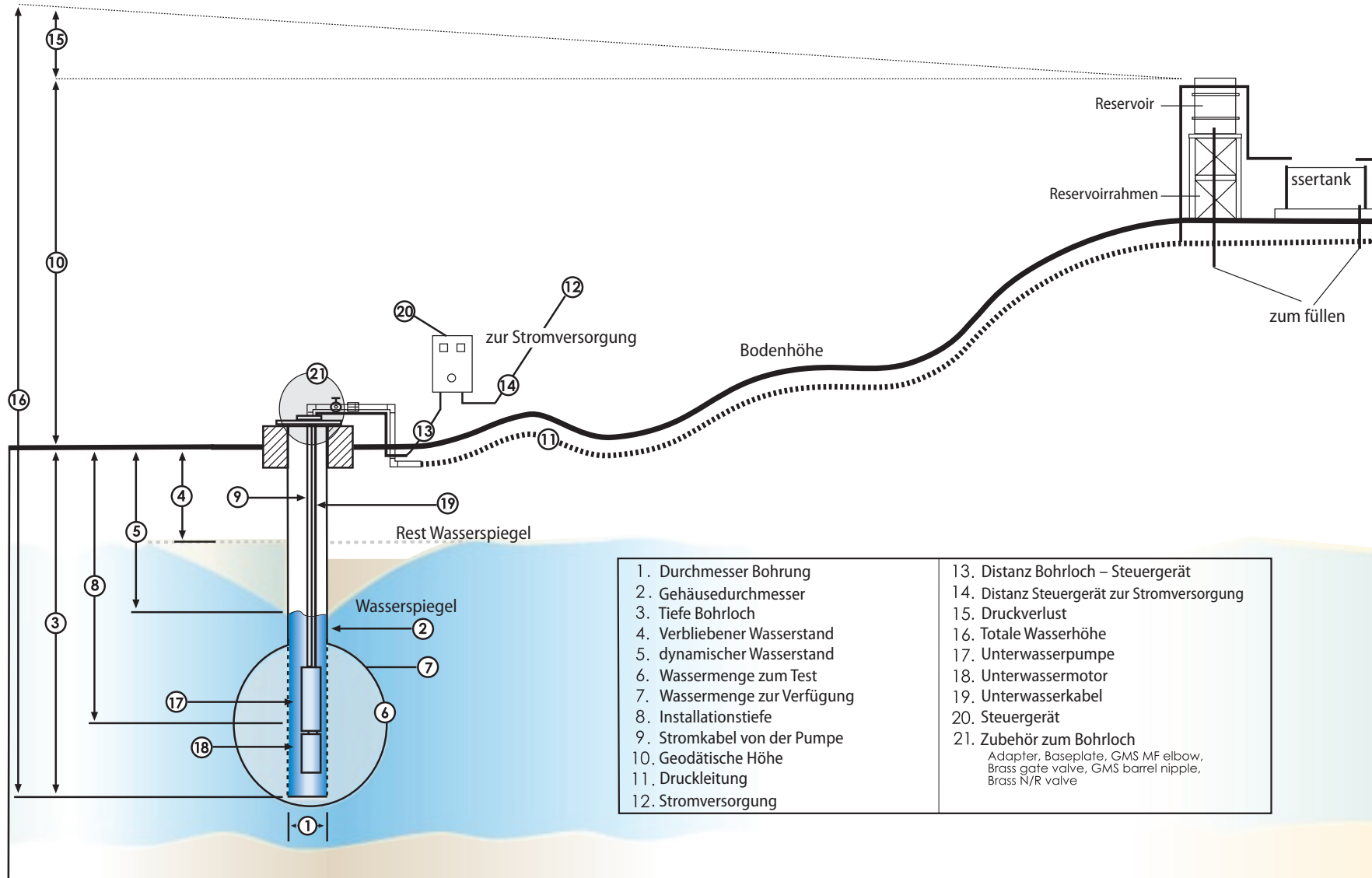

# Pumpen Projekt

## Projekt 1: .....

Item	Description	Material	Item	Description
1	Durchmesser Bohrloch		15	Druckverlust
2	Gehäuse Durchmesser		16	Total Meter Wasserhöhe
3	Tiefe Bohrloch		17	Unterwasserpumpe
4	Rest Wasserspiegel		18	Unterwassermotor
5	dynamischer Wasserstand		19	Unterwasserkabel
6	Wassermenge zum Test		20	Steuergerät
7	Wassermenge zur Verfügung			
8	Installationstiefe		21	Bohrloch Zubehör
9	Stromkabel von der Pumpe			Adapter
10	Geodätische Höhe			Grundplatte
11	Material der Druckleitung			Elbogen
	Länge der Druckleitung			Absperrhahn aus Bronze
12	Stromversorgung			Rohrnippel aus Bronze
13	Distanz Bohrloch – Steuergerät			Schieber aus Bronze
14	Distanz Steuergerät zur Stromversorgung			

## Projekt 2: .....

Item	Description	Material	Item	Description
1	Durchmesser Bohrloch		15	Druckverlust
2	Gehäuse Durchmesser		16	Total Meter Wasserhöhe
3	Tiefe Bohrloch		17	Unterwasserpumpe
4	Rest Wasserspiegel		18	Unterwassermotor
5	dynamischer Wasserstand		19	Unterwasserkabel
6	Wassermenge zum Test		20	Steuergerät
7	Wassermenge zur Verfügung			
8	Installationstiefe		21	Bohrloch Zubehör
9	Stromkabel von der Pumpe			Adapter
10	Geodätische Höhe			Grundplatte
11	Material der Druckleitung			Elbogen
	Länge der Druckleitung			Absperrhahn aus Bronze
12	Stromversorgung			Rohrnippel aus Bronze
13	Distanz Bohrloch – Steuergerät			Schieber aus Bronze
14	Distanz Steuergerät zur Stromversorgung			

## Projekt 3: .....

Item	Description	Material	Item	Description
1	Durchmesser Bohrloch		15	Druckverlust
2	Gehäuse Durchmesser		16	Total Meter Wasserhöhe
3	Tiefe Bohrloch		17	Unterwasserpumpe
4	Rest Wasserspiegel		18	Unterwassermotor
5	dynamischer Wasserstand		19	Unterwasserkabel
6	Wassermenge zum Test		20	Steuergerät
7	Wassermenge zur Verfügung			
8	Installationstiefe		21	Bohrloch Zubehör
9	Stromkabel von der Pumpe			Adapter
10	Geodätische Höhe			Grundplatte
11	Material der Druckleitung			Elbogen
	Länge der Druckleitung			Absperrhahn aus Bronze
12	Stromversorgung			Rohrnippel aus Bronze
13	Distanz Bohrloch – Steuergerät			Schieber aus Bronze
14	Distanz Steuergerät zur Stromversorgung			

# UG1A - Kennlinien

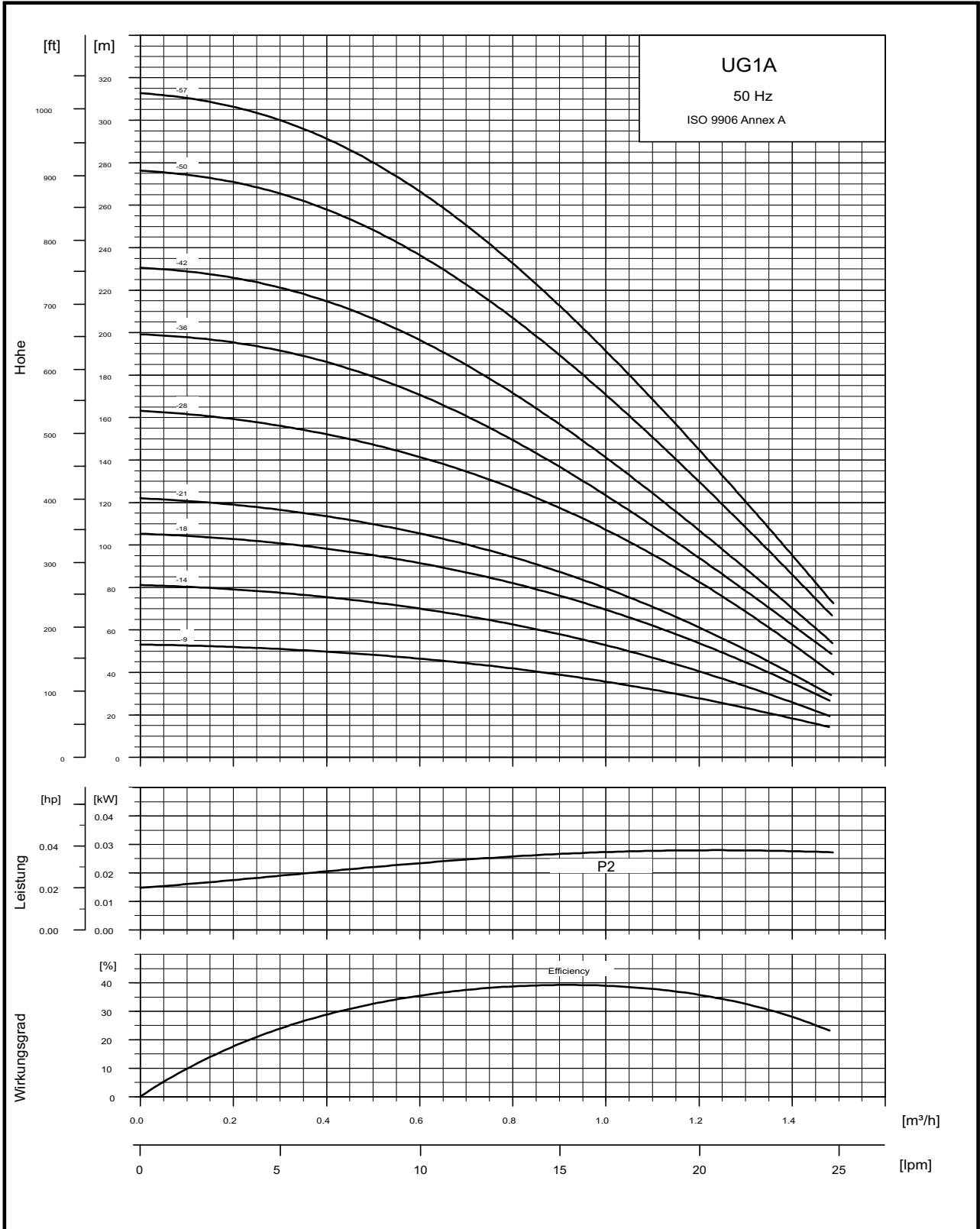

# UG1A - Technische Informationen

## Dimension und Gewicht

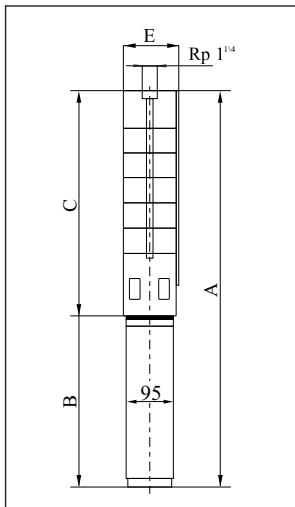

E = Max. Dia of Pump inclusive of cable guard & motor.

Pumpentyp	Motor		Dimensionen (mm)						Netto Gewicht (kg)		
	Typ UGM.... (inch/HP)	Power (KW/HP)	C	B		A		D	E	1x230V	3x230V 3x400V
				1x230V	3x230V 3x400V	1x230V	3x230V 3x400V				
UG1A-9	UGM4/0.5	0.37 / 0.5	356	427	531	783	887	96	98	16.4	17.9
UG1A-14	UGM4/0.5	0.37 / 0.5	461	427	531	888	992	96	98	17.2	3.7
UG1A-18	UGM4/0.75	0.55 / 0.75	545	447	-	992	-	96	98	17.9	-
UG1A-21	UGM4/0.75	0.55 / 0.75	608	447	-	1055	-	96	98	18.5	-
UG1A-28	UGM4/1	0.75 / 1	755	477	-	1232	-	96	98	20.7	-
UG1A-36	UGM4/1.5	1.1 / 1.5	946	512	477	1458	1423	96	98	25.4	26.9
UG1A-42	UGM4/1.5	1.1 / 1.5	1072	512	477	1584	1549	96	98	26.8	28.3
UG1A-50	UGM4/2	1.5 / 2	1240	579	599	1819	1839	96	98	31	37
UG1A-57	UGM4/2	1.5 / 2	1387	579	599	1966	1986	96	98	21.6	38.6

- Auf Anfrage

# UG2A - Kennlinien

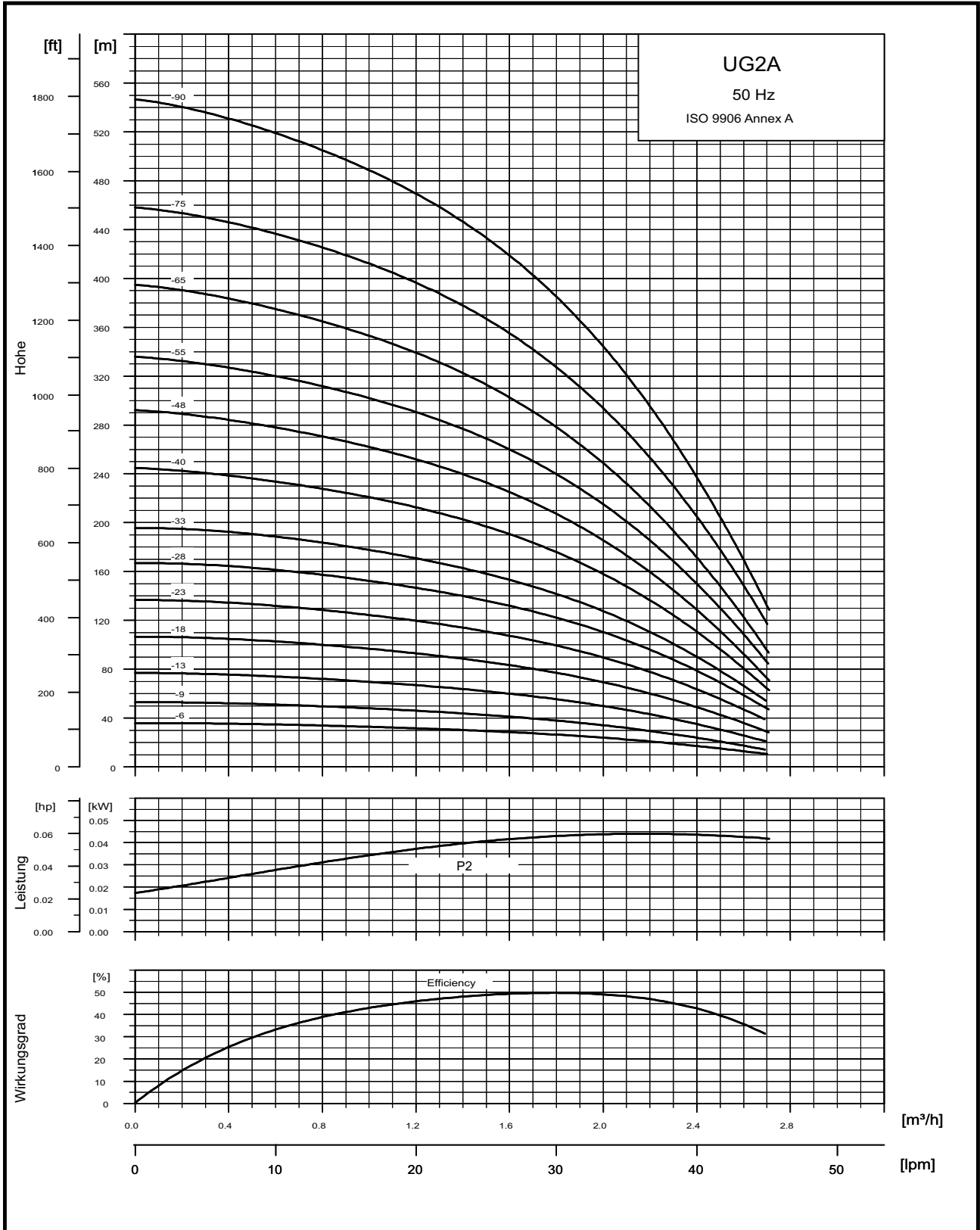



# UG2A - Technische Informationen

## Dimension und Gewicht

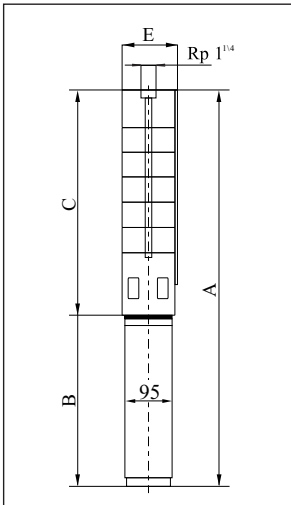

E = Max. Dia of Pump inclusive of cable guard & motor.

Pumpentyp	Motor		Dimensionen (mm)						Netto Gewicht (kg)		
	Typ UGM.... (inch/HP)	Power (KW/HP)	C	B		A		D	E	1x230V	3x230V 3x400V
				1x230V	3x230V 3x400V	1x230V	3x230V 3x400V				
UG2A-6	UGM4/0.5	0.37 / 0.5	293	427	531	720	824	96	98	15.9	17.4
UG2A-9	UGM4/0.5	0.37 / 0.5	356	427	531	783	887	96	98	16.5	18
UG2A-13	UGM4/0.75	0.55 / 0.75	440	447	-	887	-	96	98	17.3	-
UG2A-18	UGM4/1.0	0.75 / 1	545	477	-	1022	-	96	98	19.2	-
UG2A-23	UGM4/1.5	1.1 / 1.5	650	512	477	1162	1127	96	98	21.2	22.7
UG2A-28	UGM4/2	1.5 / 2	755	579	599	1334	1354	96	98	23.6	29.6
UG2A-33	UGM4/2	1.5 / 2	883	579	599	1462	1482	96	98	26.7	32.7
UG2A-40	UGM4/3	2.2 / 3	1030	657	637	1687	1667	96	98	39.5	35.5
UG2A-48	UGM4/3	2.2 / 3	1198	657	637	1855	1835	96	98	41.5	37.5
UG2A-55	UGM4/4	3 / 4	1345		677		2022	96	98		41
UG2A-65	UGM4/4	3 / 4	1555		677		2232	96	98		43.3
UG2A-75	UGM4/5.5	4 / 5.5	2140		737		2877	96	142		-
UG2A-90	UGM4/5.5	4 / 5.5	2455		737		3192	96	142		-

- Pumpe mit äusserem Stahlrohr.
- Auf Anfrage

# UG3A - Kennlinien

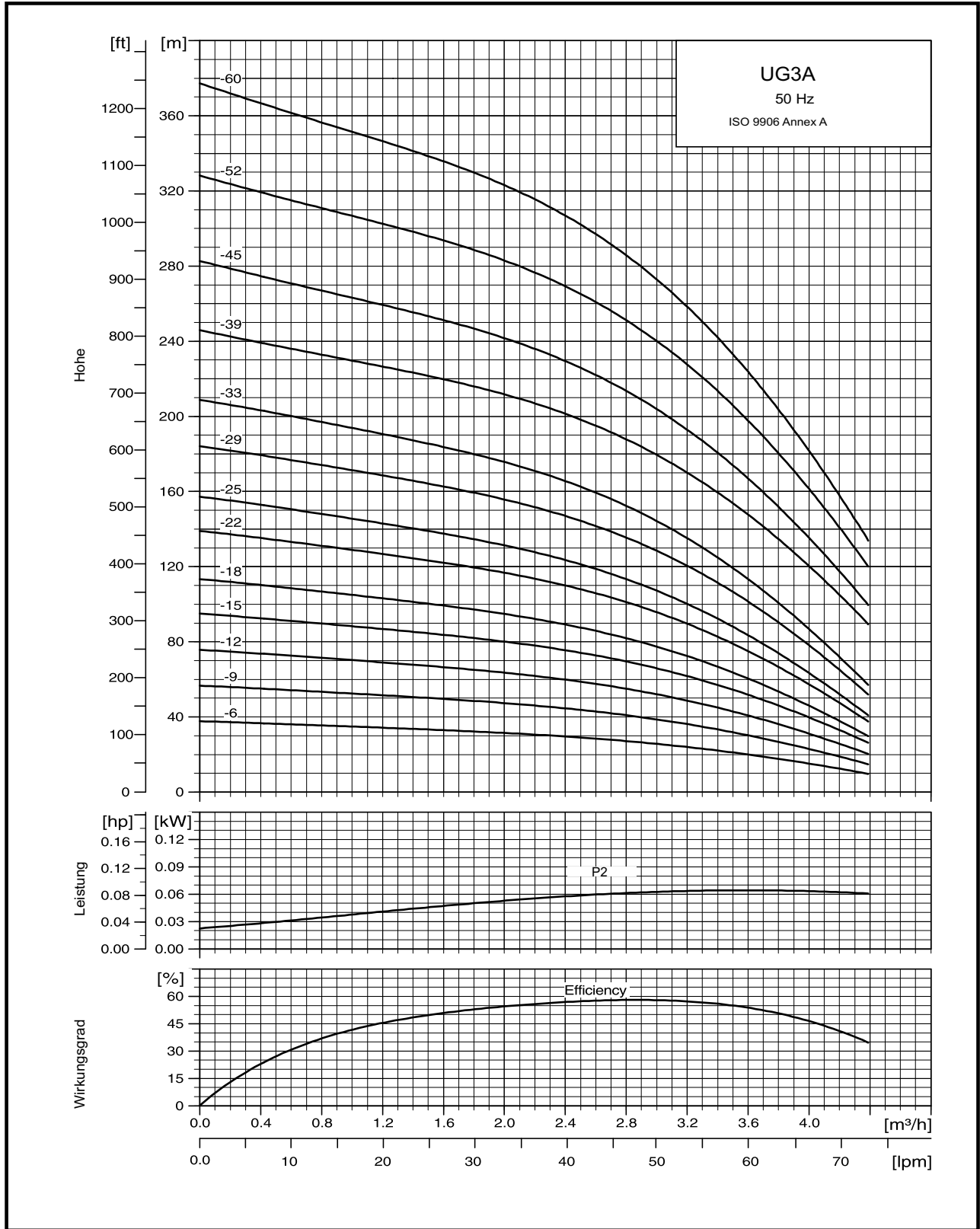

# UG3A - Technische Informationen

## Dimension und Gewicht

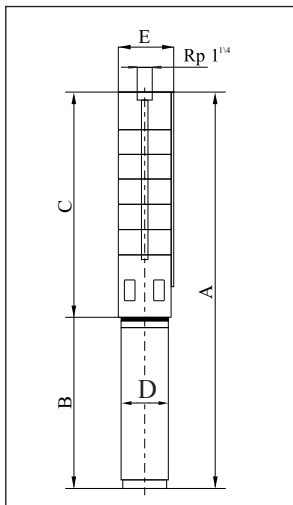

E = Max. Dia of Pump inclusive of cable guard & motor.

Pumpentyp	Motor		Dimensionen (mm)						Netto Gewicht (kg)		
	Typ UGM.... (inch/HP)	Power (KW/HP)	C	B		A		D	E	1x230V	3x230V 3x400V
				1x230V	3x230V 3x400V	1x230V	3x230V 3x400V				
UG3A-6	UGM4/0.5	0.37 / 0.5	293	427	531	720	824	96	98	15.9	17.4
UG3A-9	UGM4/0.75	0.55 / 0.75	356	447	-	803	-	96	98	16.5	-
UG3A-12	UGM4/1	0.75 / 1	419	477	-	896	-	96	98	18.1	-
UG3A-15	UGM4/1.5	1.1 / 1.5	482	512	477	994	959	96	98	19.7	21.2
UG3A-18	UGM4/1.5	1.1 / 1.5	545	512	477	1057	1022	96	98	20.2	21.7
UG3A-22	UGM4/2	1.5 / 2	629	579	599	1208	1228	96	98	22.5	28.5
UG3A-25	UGM4/2	1.5 / 2	692	579	599	1271	1291	96	98	23.1	29.1
UG3A-29	UGM4/3	2.2 / 3	776	657	637	1433	1413	96	98	34.8	30.8
UG3A-33	UGM4/3	2.2 / 3	883	657	637	1540	1520	96	98	37.7	33.7
UG3A-39	UGM4/4	3 / 4	1009		677		1686	96	98		37.2
UG3A-45	UGM4/4	3 / 4	1135		677		1812	96	98		38.7
UG3A-52	UGM4/5.5	4 / 5.5	1282		737		2019	96	98		43.7
UG3A-60	UGM4/5.5	4 / 5.5	1450		737		2187	96	98		45.5

- Auf Anfrage

# UG5A - Kennlinien

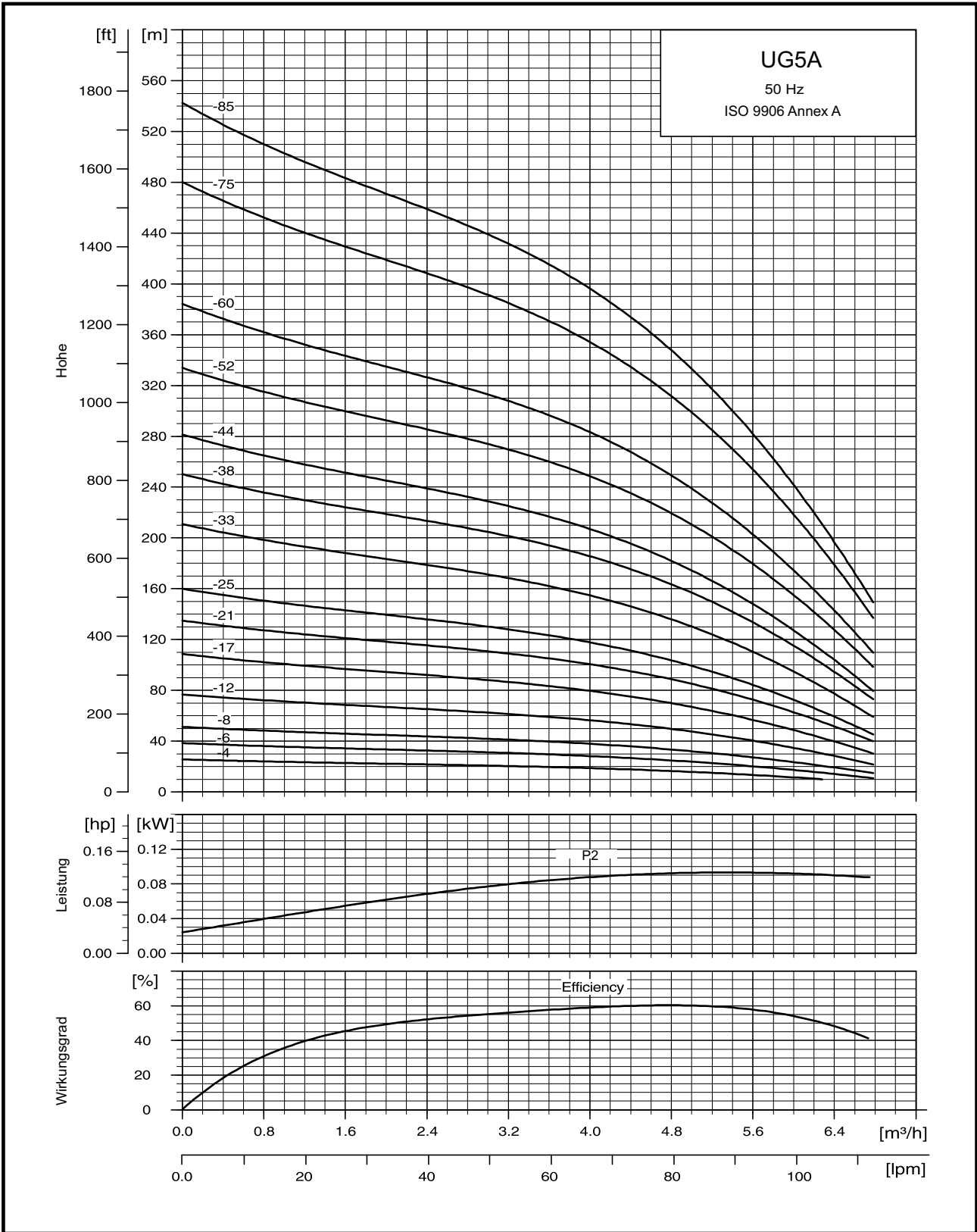

# UG5A - Technische Informationen

## Dimension und Gewicht

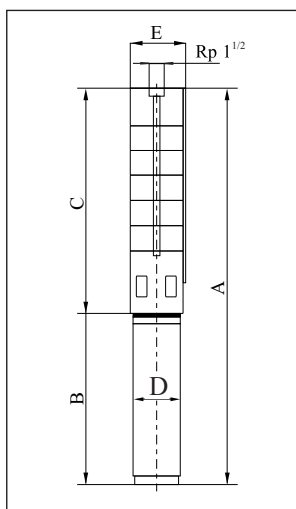

E = Max. Dia of Pump inclusive of cable guard & motor.

Pumpentyp	Motor		Dimensionen (mm)						Netto Gewicht (kg)		
	Typ UGM.... (inch/HP)	Power (KW/HP)	C	B		A		D	E	1x230V	3x230V 3x400V
				1x230V	3x230V 3x400V	1x230V	3x230V 3x400V				
UG5A-4	UGM4/0.5	0.37 / 0.5	251	427	531	678	782	96	98	15.5	17
UG5A-6	UGM4/0.75	0.55 / 0.75	293	447	-	740	-	96	98	15.9	-
UG5A-8	UGM4/1	0.75 / 1	335	477	-	812	-	96	98	17.3	-
UG5A-12	UGM4/1.5	1.1 / 1.5	419	512	477	931	896	96	98	19.1	20.6
UG5A-17	UGM4/2	1.5 / 2	524	579	599	1103	1123	96	98	21.5	27.5
UG5A-21	UGM4/3	2.2 / 3	608	657	637	1265	1245	96	98	33.3	29.3
UG5A-25	UGM4/3	2.2 / 3	692	657	637	1349	1329	96	98	34	30
UG5A-33	UGM4/4	3 / 4	868		677		1545	96	98		35.6
UG5A-38	UGM4/5.5	4 / 5.5	973		737		1710	96	98		39.9
UG5A-44	UGM4/5.5	4 / 5.5	1099		737		1836	96	98		41.4
UG5A-52	UGM4/7.5	5.5 / 7.5	1362		877		2239	96	98		51.05
UG5A-60	UGM4/7.5	5.5 / 7.5	1530		877		2407	96	98		52.7
UG5A-52	UGM6/7.5	5.5 / 7.5	1424		676		2100	144	136		64.1
UG5A-60	UGM6/7.5	5.5 / 7.5	1592		676		2268	144	136		65.75
UG5A-75	UGM6/10	7.5 / 10	1907		706		2613	144	142		-
UG5A-85	UGM6/10	7.5 / 10	2117		706		2823	144	142		-

- Pumpe mit äusserem Stahlrohr.
- Auf Anfrage

# UG8A - Kennlinien

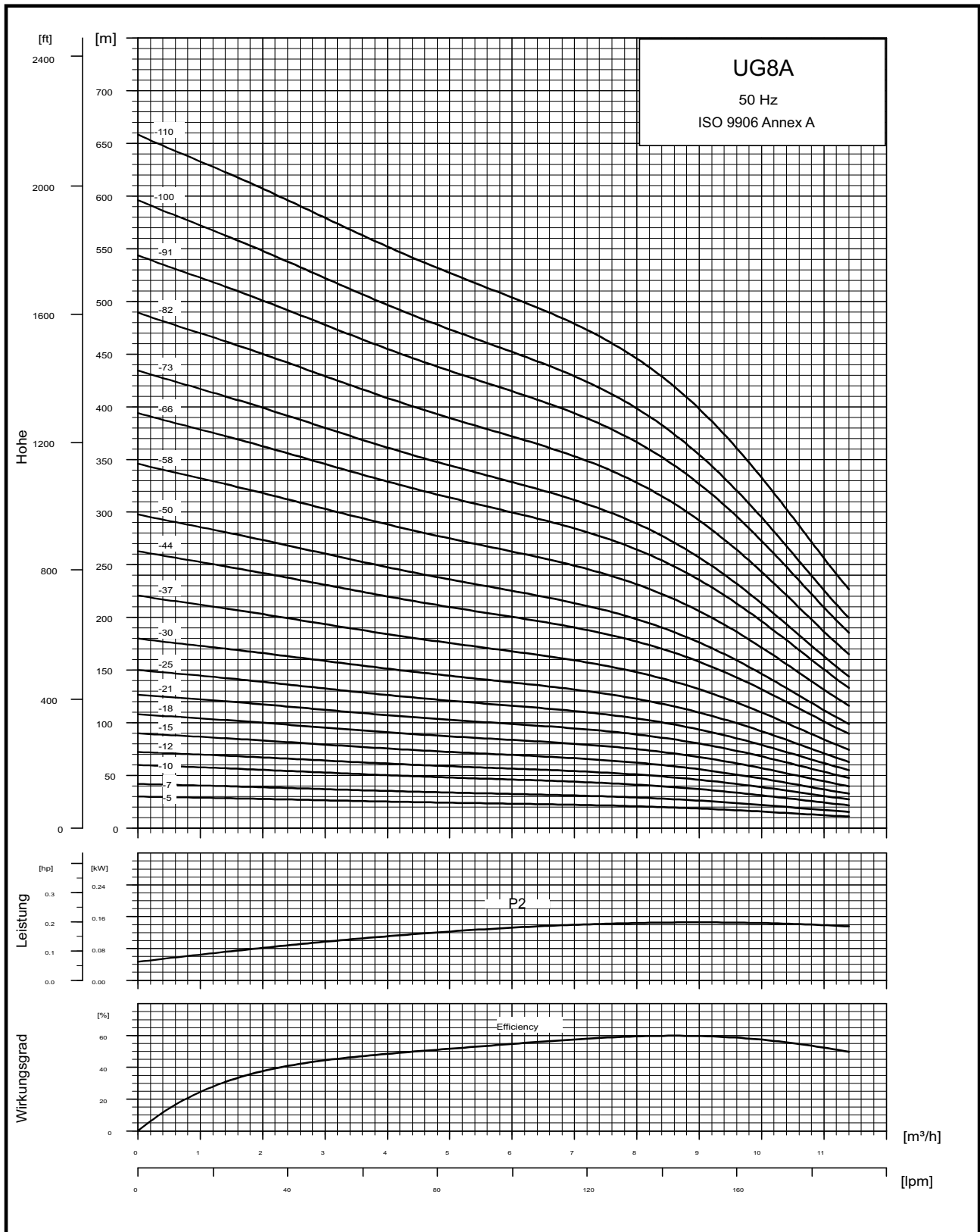

# UG8A - Technische Informationen

## Dimension und Gewicht

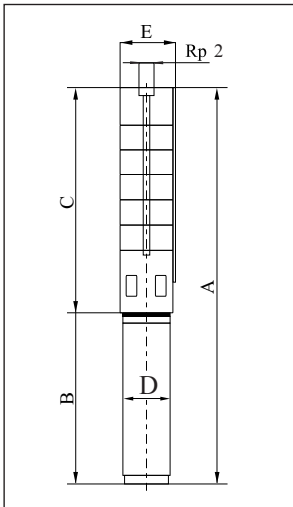

E = Max. Dia of Pump inclusive of cable guard & motor.

Pumpentyp	Motor		Dimensionen (mm)						Netto Gewicht (kg)		
	Typ UGM.... (inch/HP)	Power (KW/HP)	C	B		A		D	E	1x230V	3x230V 3x400V
				1x230V	3x230V 3x400V	1x230V	3x230V 3x400V				
UG8A-5	UGM4/1	0.75 / 1	412	477	-	889	-	96	98	18.8	-
UG8A-7	UGM4/1.5	1.1 / 1.5	496	512	-	1008	-	96	98	20.8	-
UG8A-10	UGM4/2	1.5 / 2	622	579	599	1201	1221	96	98	23.8	29.8
UG8A-12	UGM4/3	2.2 / 3	706	657	637	1363	1343	96	98	35.8	31.8
UG8A-15	UGM4/3	2.2 / 3	832	657	637	1489	1469	96	98	37.3	33.3
UG8A-18	UGM4/4	3 / 4	958		677		1635	96	98		36.8
UG8A-21	UGM4/5.5	4 / 5.5	1084		737		1821	96	98		41.3
UG8A-25	UGM4/5.5	4 / 5.5	1252		737		1989	96	98		43.3
UG8A-30	UGM4/7.5	5.5 / 7.5	1462		877		2339	96	98		53.1
UG8A-37	UGM4/7.5	5.5 / 7.5	1753		877		2630	96	98		56.6
UG8A-44	UGM4/10	7.5 / 10	2050		1017		3067	96	98		66.8
UG8A-50	UGM4/10	7.5 / 10	2302		1017		3319	96	98		69.8
UG8A-30	UGM6/7.5	5.5 / 7.5	1560		676		2236	144	136		66.5
UG8A-37	UGM6/7.5	5.5 / 7.5	1840		676		2516	144	136		69.85
UG8A-44	UGM6/10	7.5 / 10	2140		706		2846	144	136		72.5
UG8A-50	UGM6/10	7.5 / 10	2390		706		3096	144	136		78.5
UG8A-58	UGM6/12.5	9.2 / 12.5	3040		736		3776	144	142		111.3
UG8A-66	UGM6/15	11 / 15	3376		776		4152	144	142		126.75
UG8A-73	UGM6/15	11 / 15	3670		776		4446	144	142		133.4
UG8A-82	UGM6/17.5	13 / 17.5	4048		826		4874	144	142		147.5
UG8A-91	UGM6/20	15 / 20	4426		866		5292	144	142		159.5
UG8A-100	UGM6/20	15 / 20	4804		866		5670	144	142		164.65
UG8A-110	UGM6/25	18.5 / 25	5224		921		6145	144	142		179

- Pumpe mit äusserem Stahlrohr.
- Auf Anfrage

## UG14A - Kennlinien

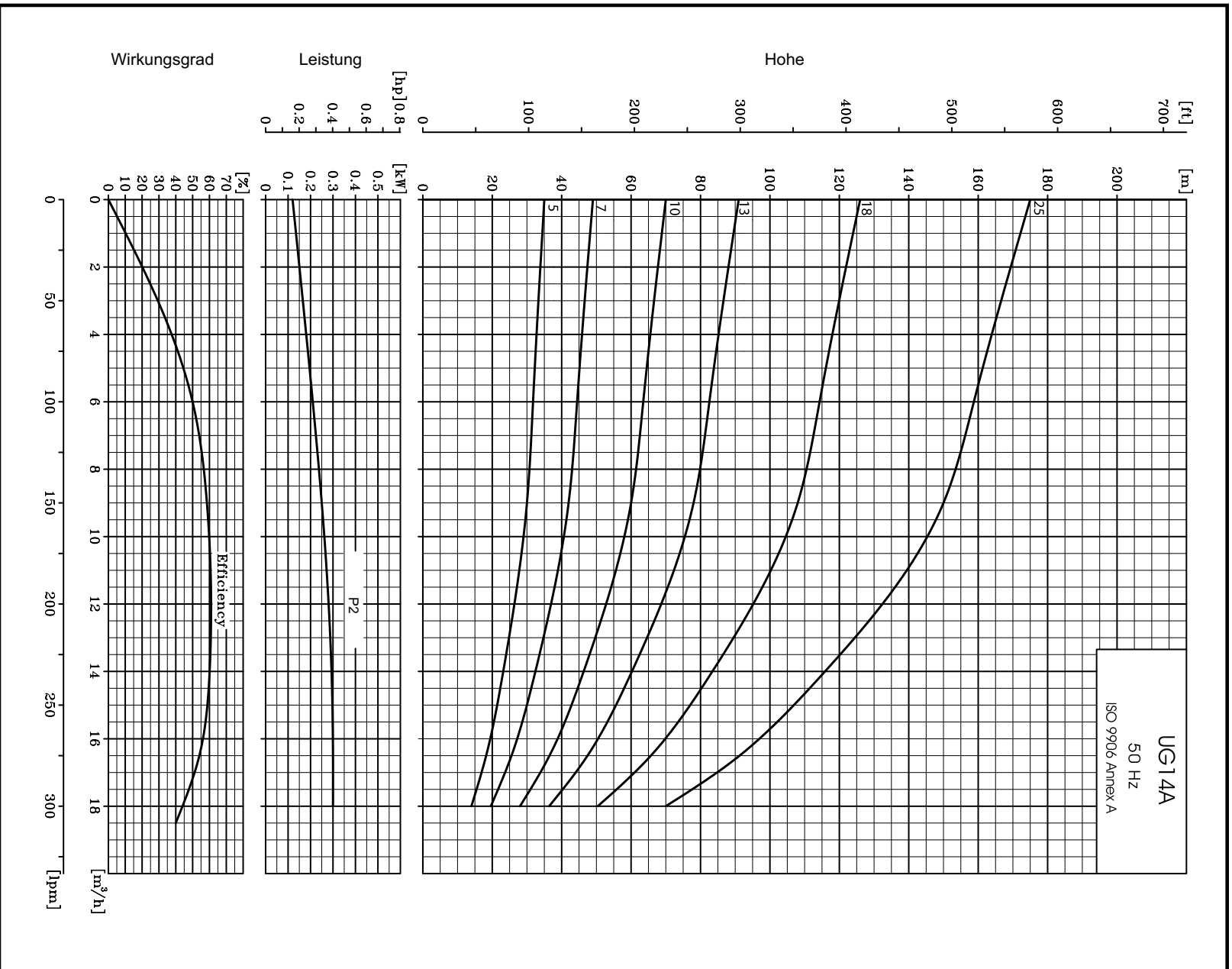



# UG14A - Technische Informationen

## Dimension und Gewicht

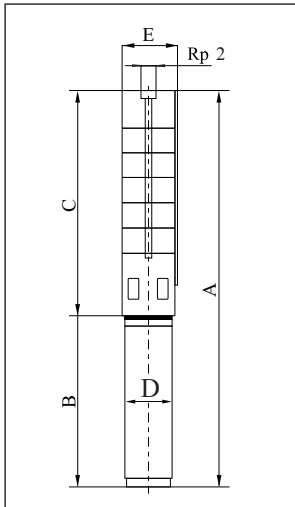

E = Max. Dia of Pump inclusive of cable guard & motor.

Pumpentyp	Motor		Dimensionen (mm)						Netto Gewicht (kg)		
	Typ UGM.... (inch/HP)	Power (KW/HP)	C	B		A		D	E	1x230V	3x230V 3x400V
				1x230V	3x230V 3x400V	1x230V	3x230V 3x400V				
UG14A-5	UGM4/2	1.5 / 2	505	299	599	804	1104	96	98	22	28
UG14A-7	UGM4/3	2.2 / 3	635	657	637	1292	1272	96	98	34.3	30.3
UG14A-10	UGM4/4	3 / 4	830		677		1507	96	98		34.2
UG14A-13	UGM4/5.5	3.7 / 5.5	1025		737		1762	96	98		39.2
UG14A-18	UGM4/7.5	5.5 / 7.5	1350		877		2227	96	98		49.7
UG14A-25	UGM4/10	7.5 / 10	1805		1017		2822	96	98		60.8
UG14A-18	UGM6/7.5	5.5 / 7.5	1450		676		2126	144	136		63.77
UG14A-25	UGM6/10	7.5 / 10	1905		706		2611	144	136		-

- Auf Anfrage

# UG17 - Kennlinien

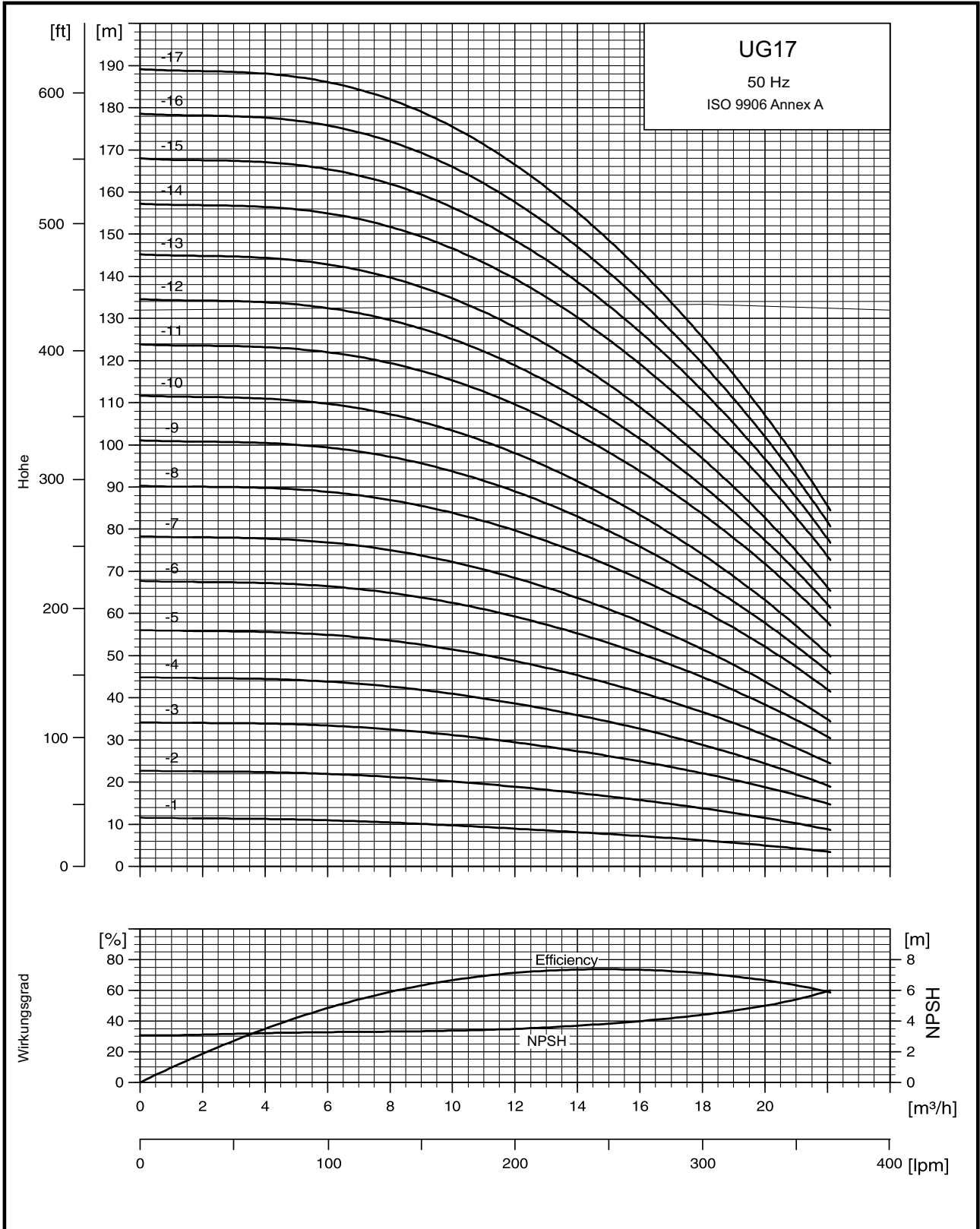

# UG17 - Kennlinien

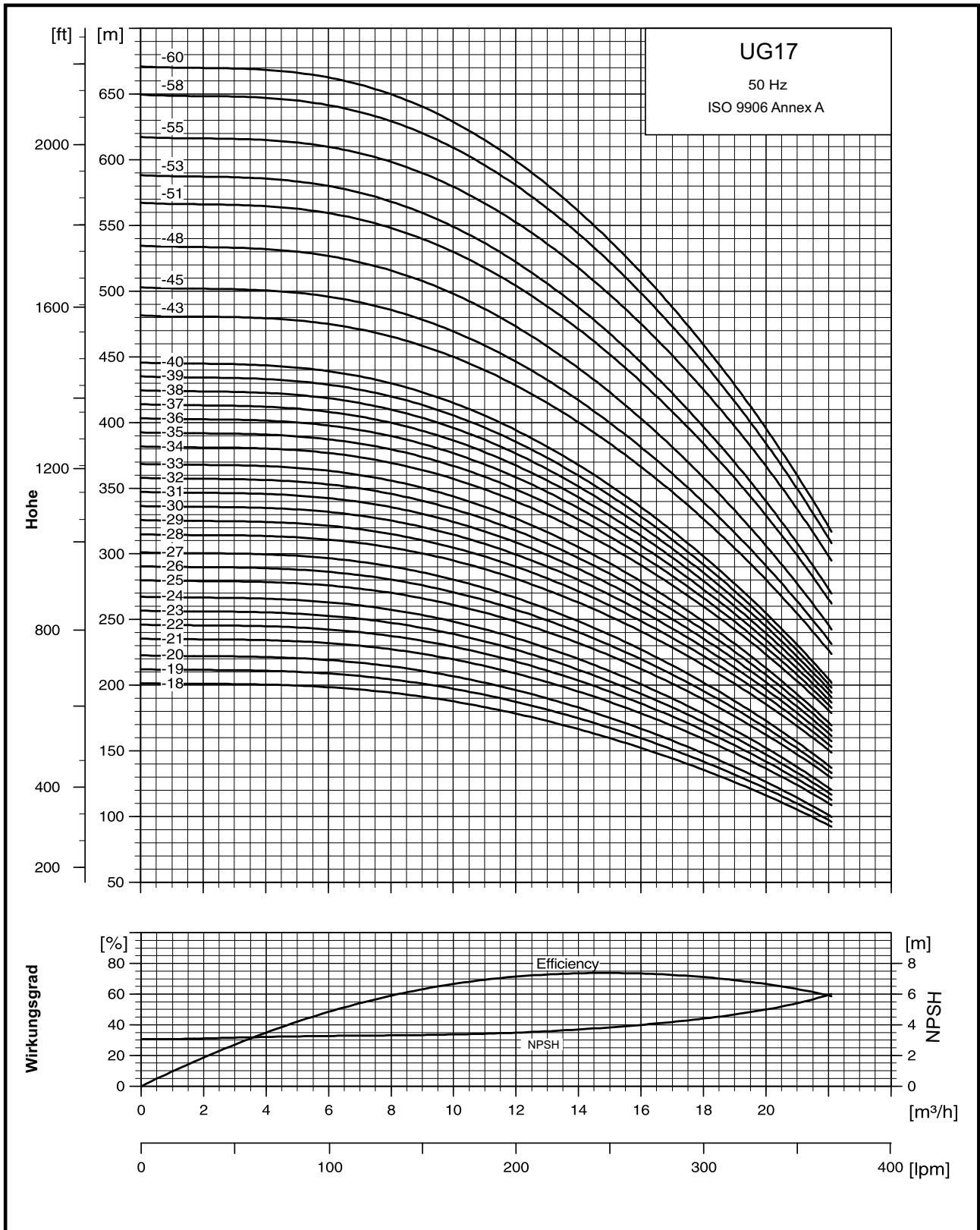

# UG17 - Technische Informationen

## Dimension und Gewicht

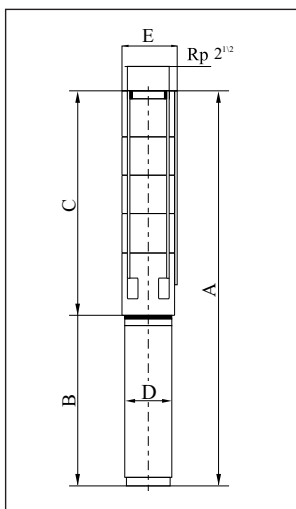

Pumpentyp	Motor		Dimensionen (mm)						Netto Gewicht (kg)			
	Typ UGM.... (inch/HP)	Power (KW/HP)	C	B		A		D	E*	E**	1x230V	3x230V 3x400V
				1x230V	3x230V 3x400V	1x230V	3x230V 3x400V					
UG17-1	UGM4/0.75	0.55 / 0.75	343	447	-	790	-	96	131		20	-
UG17-2	UGM4/1.5	1.1 / 1.5	403	512	477	915	880	96	131		23.2	23.4
UG17-3	UGM4/3	2.2 / 3	435	657	637	1092	1072	96	131		35.3	31.3
UG17-4	UGM4/3	2.2 / 3	524	657	637	1181	1161	96	131		37.3	33.3
UG17-5	UGM4/4	3 / 4	585		677		1262	96	131			36.8
UG17-6	UGM4/5.5	4 / 5.5	616		737		1353	96	131			41.2
UG17-7	UGM4/5.5	4 / 5.5	677		737		1414	96	131			42.7
UG17-8	UGM4/7.5	5.5 / 7.5	737		877		1614	96	131			50.4
UG17-9	UGM4/7.5	5.5 / 7.5	798		877		1675	96	131			51.7
UG17-10	UGM4/7.5	5.5 / 7.5	858		877		1735	96	131			54.3
UG17-11	UGM4/10	7.5 / 10	919		1017		1936	96	142			61.2
UG17-12	UGM4/10	7.5 / 10	979		1017		1996	96	142			62.6
UG17-13	UGM4/10	7.5 / 10	1040		1017		2057	96	142			64
UG17-8	UGM6/7.5	5.5 / 7.5	753		676		1429	144	142			63
UG17-9	UGM6/7.5	5.5 / 7.5	814		676		1490	144	142			64.6
UG17-10	UGM6/7.5	5.5 / 7.5	874		676		1550	144	142			66
UG17-11	UGM6/10	7.5 / 10	935		706		1641	144	142			69.5
UG17-12	UGM6/10	7.5 / 10	995		706		1701	144	142			71
UG17-13	UGM6/10	7.5 / 10	1056		706		1762	144	142			72.4
UG17-14	UGM6/12.5	9.2 / 12.5	1116		736		1852	144	142	142		75.6
UG17-15	UGM6/12.5	9.2 / 12.5	1177		736		1913	144	142	142		77
UG17-16	UGM6/12.5	9.2 / 12.5	1237		736		1973	144	142	142		78.5
UG17-17	UGM6/12.5	9.2 / 12.5	1311		736		2047	144	142	142		80
UG17-18	UGM6/15	11 / 15	1358		776		2134	144	142	142		89.2
UG17-19	UGM6/15	11 / 15	1419		776		2195	144	142	142		90.7
UG17-20	UGM6/15	11 / 15	1492		776		2268	144	142	142		92
UG17-21	UGM6/17.5	13 / 17.5	1540		826		2366	144	142	142		99.2
UG17-22	UGM6/17.5	13 / 17.5	1613		826		2439	144	142	142		100.5
UG17-23	UGM6/17.5	13 / 17.5	1661		826		2487	144	142	142		102
UG17-24	UGM6/17.5	13 / 17.5	1734		826		2560	144	142	142		103.5
UG17-25	UGM6/20	15 / 20	1782		866		2648	144	142	142		108.4
UG17-26	UGM6/20	15 / 20	1842		866		2708	144	142	142		109.8
UG17-27	UGM6/20	15 / 20	1916		866		2782	144	142	142		111.3
UG17-28	UGM6/25	18.5 / 25	1963		921		2884	144	142	142		118.5
UG17-29	UGM6/25	18.5 / 25	2037		921		2958	144	142	142		120
UG17-30	UGM6/25	18.5 / 25	2084		921		3005	144	142	142		121.4
UG17-31	UGM6/25	18.5 / 25	2158		921		3079	144	142	142		123
UG17-32	UGM6/25	18.5 / 25	2205		921		3126	144	142	142		124.3
UG17-33	UGM6/25	18.5 / 25	2279		921		3200	144	142	142		125.8
UG17-34	UGM6/30	22 / 30	2326		996		3322	144	142	142		137
UG17-35	UGM6/30	22 / 30	2387		996		3383	144	142	142		138.9
UG17-36	UGM6/30	22 / 30	2460		996		3456	144	142	142		140
UG17-37	UGM6/30	22 / 30	2508		996		3504	144	142	142		141.8
UG17-38	UGM6/30	22 / 30	2581		996		3577	144	142	142		142.8
UG17-39	UGM6/30	22 / 30	2629		996		3625	144	142	142		144.7
UG17-40	UGM6/30	22 / 30	2702		996		3698	144	142	142		145.7
• UG17-43	UGM6/35	26 / 35	3196		1056		4252	144	167			-
• UG17-45	UGM6/35	26 / 35	3317		1056		4373	144	167			-
• UG17-48	UGM6/35	26 / 35	3499		1056		4555	144	167			-
• UG17-51	UGM6/40	30 / 40	3680		1176		4856	144	167			-
• UG17-53	UGM6/40	30 / 40	3749		1176		4925	144	167			-
• UG17-55	UGM8/50	37 / 50	3870		1010		4880	190	183			-
• UG17-58	UGM8/50	37 / 50	4052		1010		5062	190	183			-
• UG17-60	UGM8/50	37 / 50	4173		1010		5183	190	183			-

• Pumpe mit äusserem Stahlrohr .

\* Maximum Durchmesser von Pumpe mit Motor und einem Kabel

\*\* Maximum Durchmesser von Pumpe mit Motor und 2 Kabeln

- Auf Anfrage

# UG17 - Leistungskurve

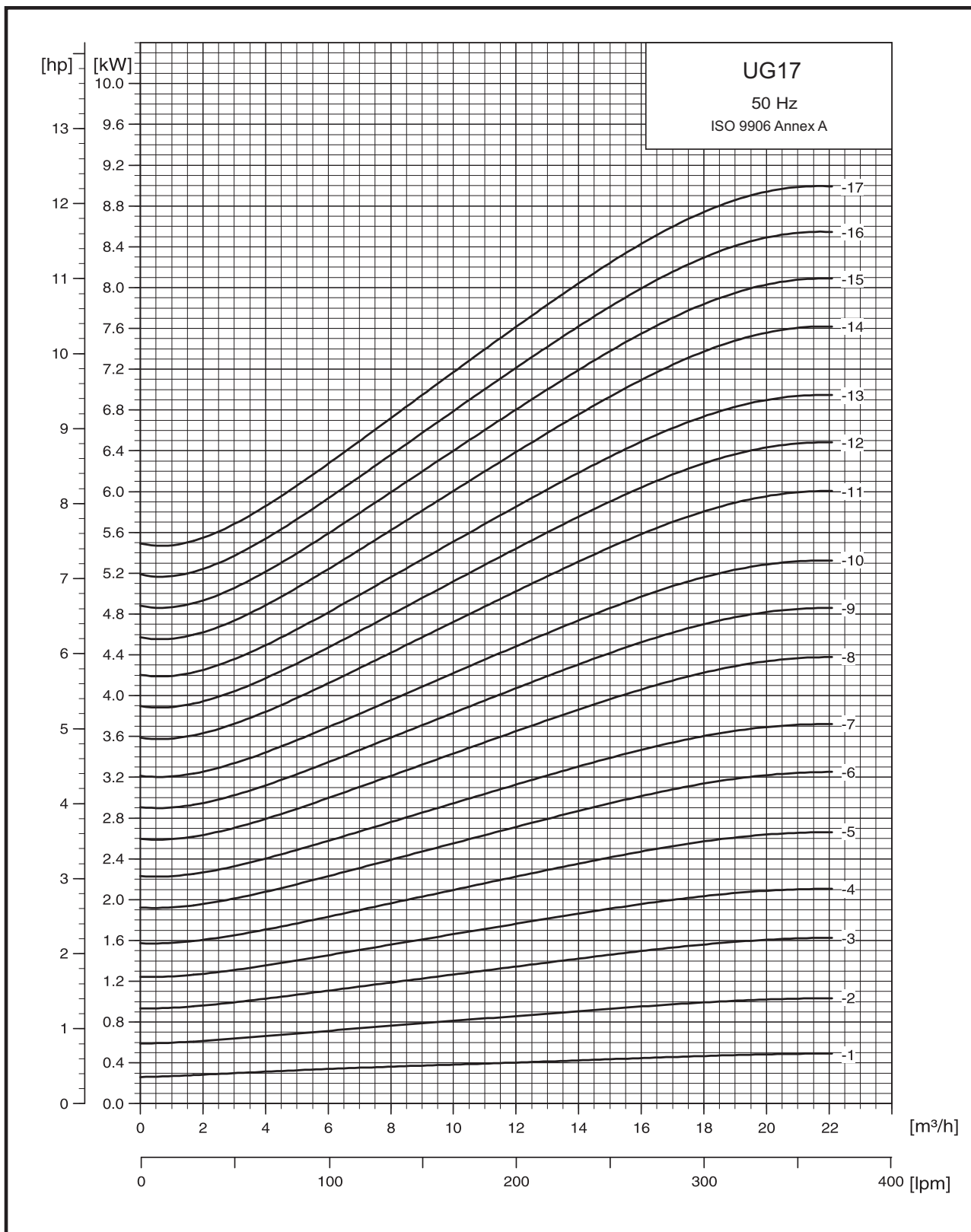

# UG17 - Leistungskurve

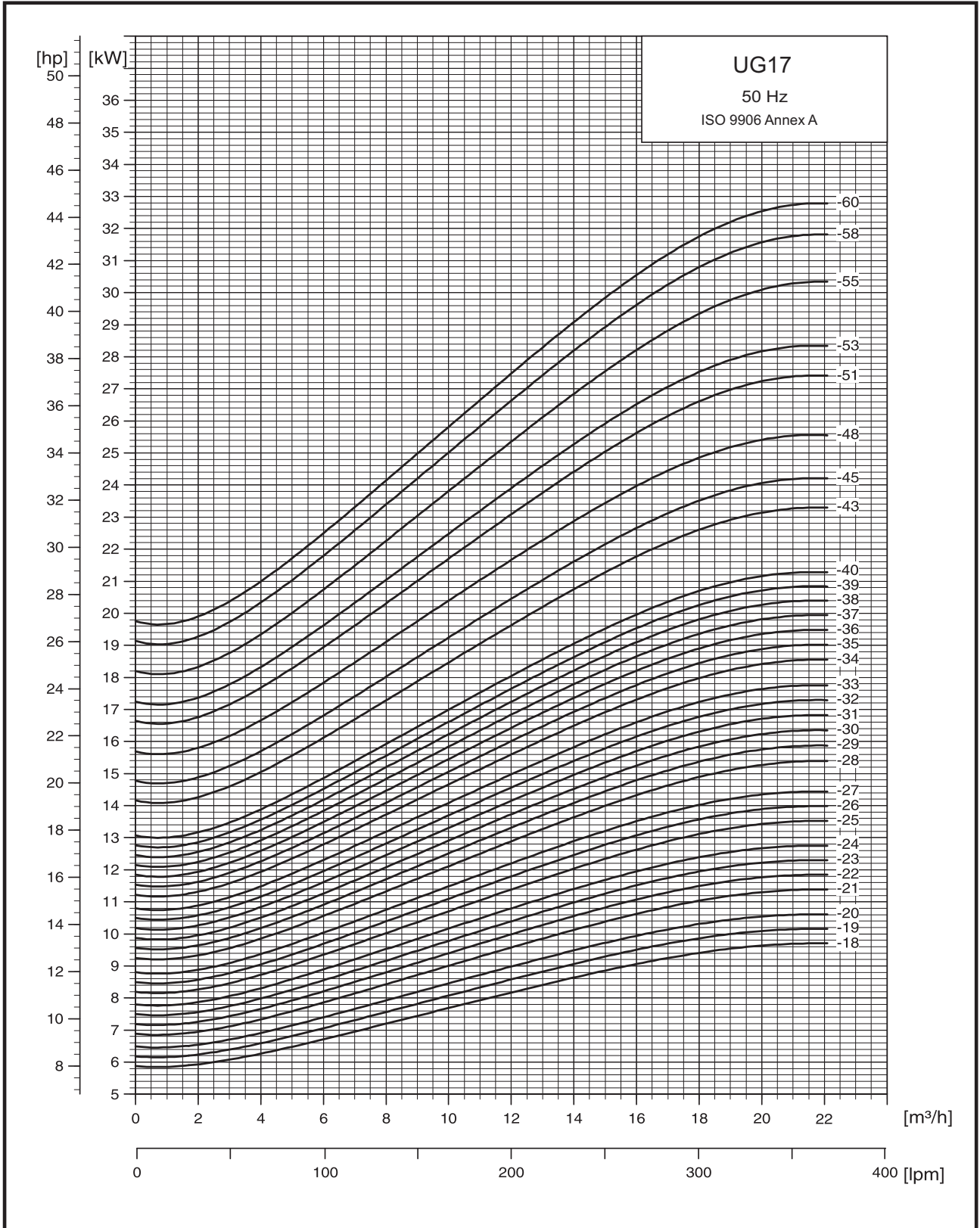

# UG30 - Kennlinien

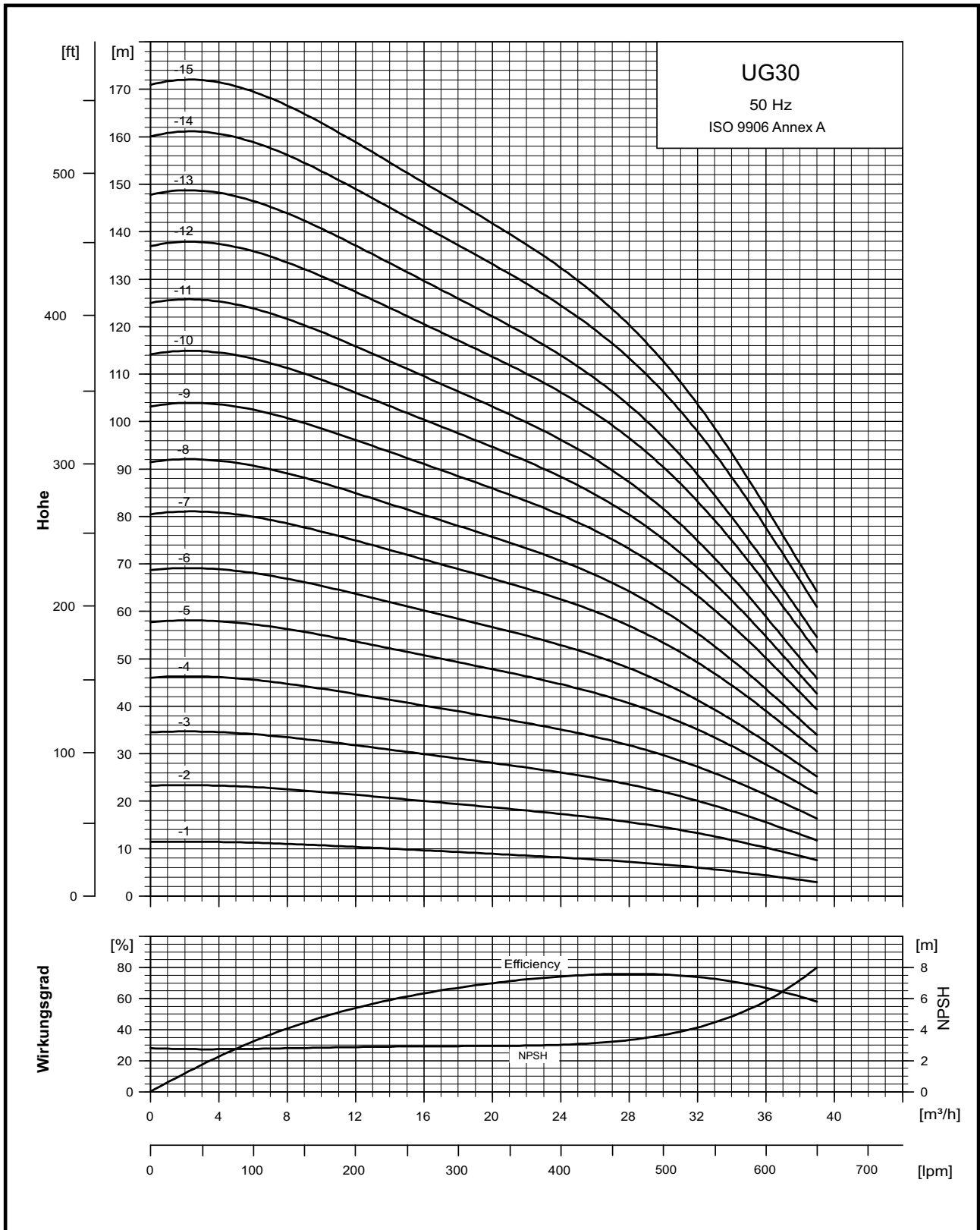

# UG30 - Kennlinien

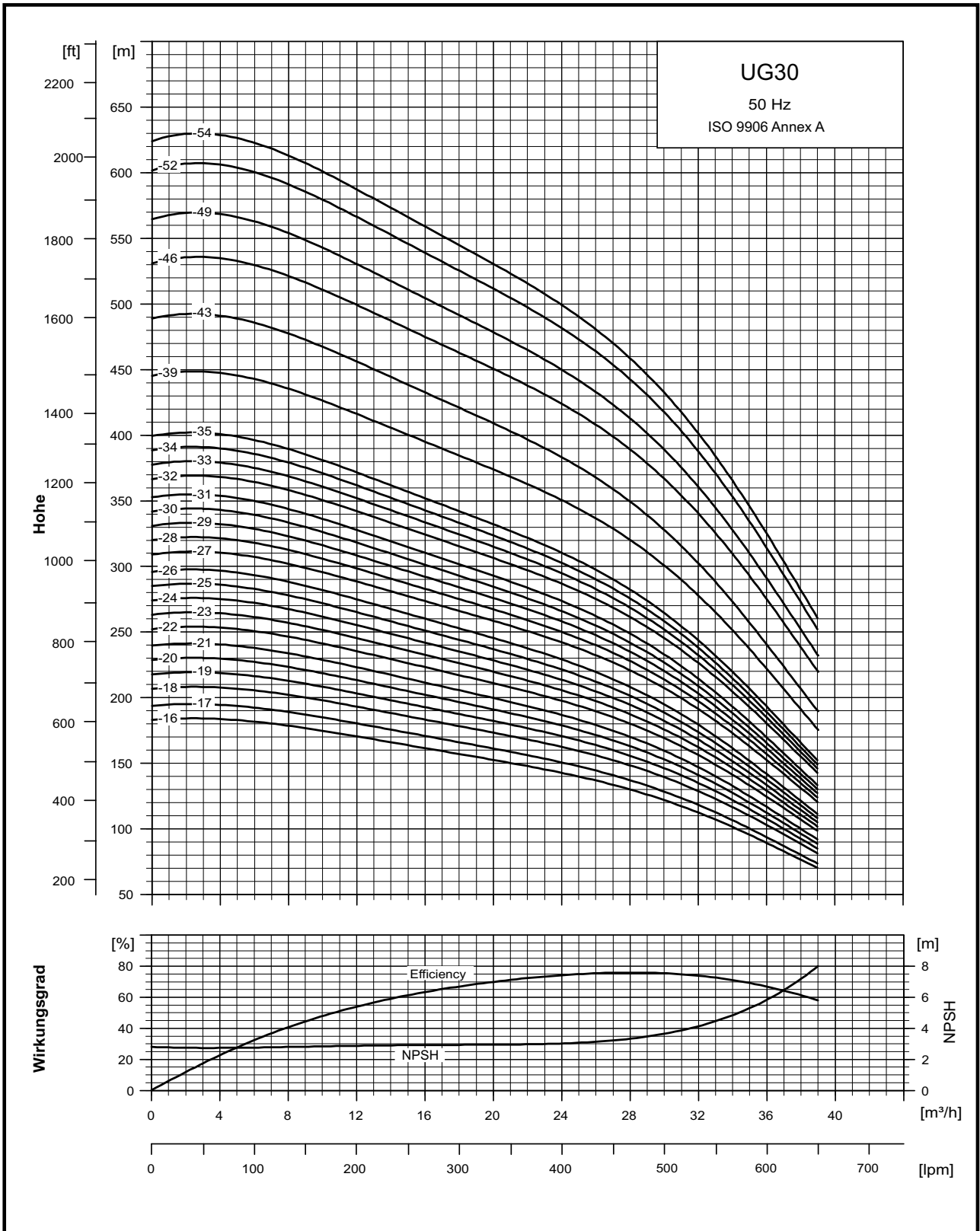



# UG30 - Technische Informationen

## Dimension und Gewicht

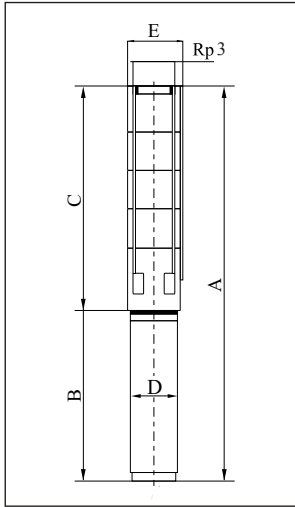

Pumpentyp	Motor		Dimensionen (mm)							Netto Gewicht (kg)		
	Typ UGM.... (inch/HP)	Power (KW/HP)	C	B		A		D	E*	E**	1x230V	3x230V 3x400V
				1x230V	3x230V 3x400V	1x230V	3x230V 3x400V					
UG30-1	UGM4/1.5	1.1 / 1.5	350	512	477	862	827	96	131		22.2	23.7
UG30-2	UGM4/3	2.2 / 3	462	657	637	1119	1099	96	131		36.5	32.4
UG30-3	UGM4/4	3 / 4	558		677		1235	96	131			34.1
UG30-4	UGM4/5.5	4 / 5.5	654		737		1391	96	131			40.8
UG30-5	UGM4/7.5	5.5 / 7.5	734		877		1611	96	131			48.6
UG30-6	UGM4/7.5	5.5 / 7.5	830		877		1707	96	131			50.4
UG30-7	UGM4/10	7.5 / 10	926		1017		1943	96	142			58.9
UG30-8	UGM4/10	7.5 / 10	1038		1017		2055	96	142	142		60.7
UG30-5	UGM6/7.5	5.5 / 7.5	750		676		1426	144	142	142		61.5
UG30-6	UGM6/7.5	5.5 / 7.5	846		676		1522	144	142	142		63.2
UG30-7	UGM6/10	7.5 / 10	842		706		1548	144	142	142		66.9
UG30-8	UGM6/10	7.5 / 10	1038		706		1744	144	142	142		68.6
UG30-9	UGM6/12.5	9.2 / 12.5	1134		736		1870	144	142	142		72.1
UG30-10	UGM6/12.5	9.2 / 12.5	1230		736		1966	144	142	142		73.8
UG30-11	UGM6/12.5	9.2 / 12.5	1326		736		2062	144	142	142		75.4
UG30-12	UGM6/15	11 / 15	1422		776		2198	144	142	142		85
UG30-13	UGM6/15	11 / 15	1518		776		2294	144	142	142		86.6
UG30-14	UGM6/17.5	13 / 17.5	1614		826		2440	144	142	142		94
UG30-15	UGM6/20	15 / 20	1710		866		2576	144	142	142		99
UG30-16	UGM6/20	15 / 20	-		-		-	-	-	-		-
UG30-17	UGM6/20	15 / 20	1902		866		2768	144	142	142		102.4
UG30-18	UGM6/25	18.5 / 25	1998		921		2919	144	142	142		110
UG30-19	UGM6/25	18.5 / 25	2094		921		3015	144	142	142		111.6
UG30-20	UGM6/25	18.5 / 25	2190		921		3111	144	142	142		113.4
UG30-21	UGM6/25	18.5 / 25	2286		921		3207	144	142	142		115
UG30-22	UGM6/30	22 / 30	2382		996		3378	144	142	142		126.6
UG30-23	UGM6/30	22 / 30	2478		996		3474	144	142	142		128.3
UG30-24	UGM6/30	22 / 30	2574		996		3570	144	142	142		129.8
UG30-25	UGM6/30	22 / 30	2670		996		3666	144	142	142		131.7
UG30-26	UGM6/30	22 / 30	2766		996		3762	144	142	142		133.2
UG30-27	UGM6/35	26 / 35	2862		1056		3918	144	142	142		143.9
UG30-28	UGM6/35	26 / 35	2958		1056		4014	144	142	142		145.6
UG30-29	UGM6/35	26 / 35	3054		1056		4110	144	142	142		147.1
UG30-30	UGM6/35	26 / 35	3150		1056		4206	144	142	142		149
UG30-31	UGM6/40	30 / 40	3246		1176		4422	144	142	142		157.7
UG30-32	UGM6/40	30 / 40	3342		1176		4518	144	142	142		159.2
UG30-33	UGM6/40	30 / 40	3438		1176		4614	144	142	142		161.1
UG30-34	UGM6/40	30 / 40	-		-		-	-	-	-		-
UG30-35	UGM6/40	30 / 40	3630		1176		4806	144	142	142		164.3
• UG30-39	UGM8/50	37 / 50	4360		1010		5370	190	-	-		264
• UG30-43	UGM8/50	37 / 50	4744		1010		5754	190	-	-		284
• UG30-46	UGM8/60	45 / 60	5032		1062		6094	190	-	-		306
• UG30-49	UGM8/60	45 / 60	5320		1062		6382	190	-	-		321
• UG30-52	UGM8/75	55 / 75	5608		1168		6776	190	-	-		348
• UG30-54	UGM8/75	55 / 75	5800		1168		6968	190	-	-		358

- Pumpe mit äusserem Stahlrohr .
- \* Maximum Durchmesser von Pumpe mit Motor und einem Kabel
- \*\* Maximum Durchmesser von Pumpe mit Motor und 2 Kabeln
- Auf Anfrage

# UG30 - Leistungskurve

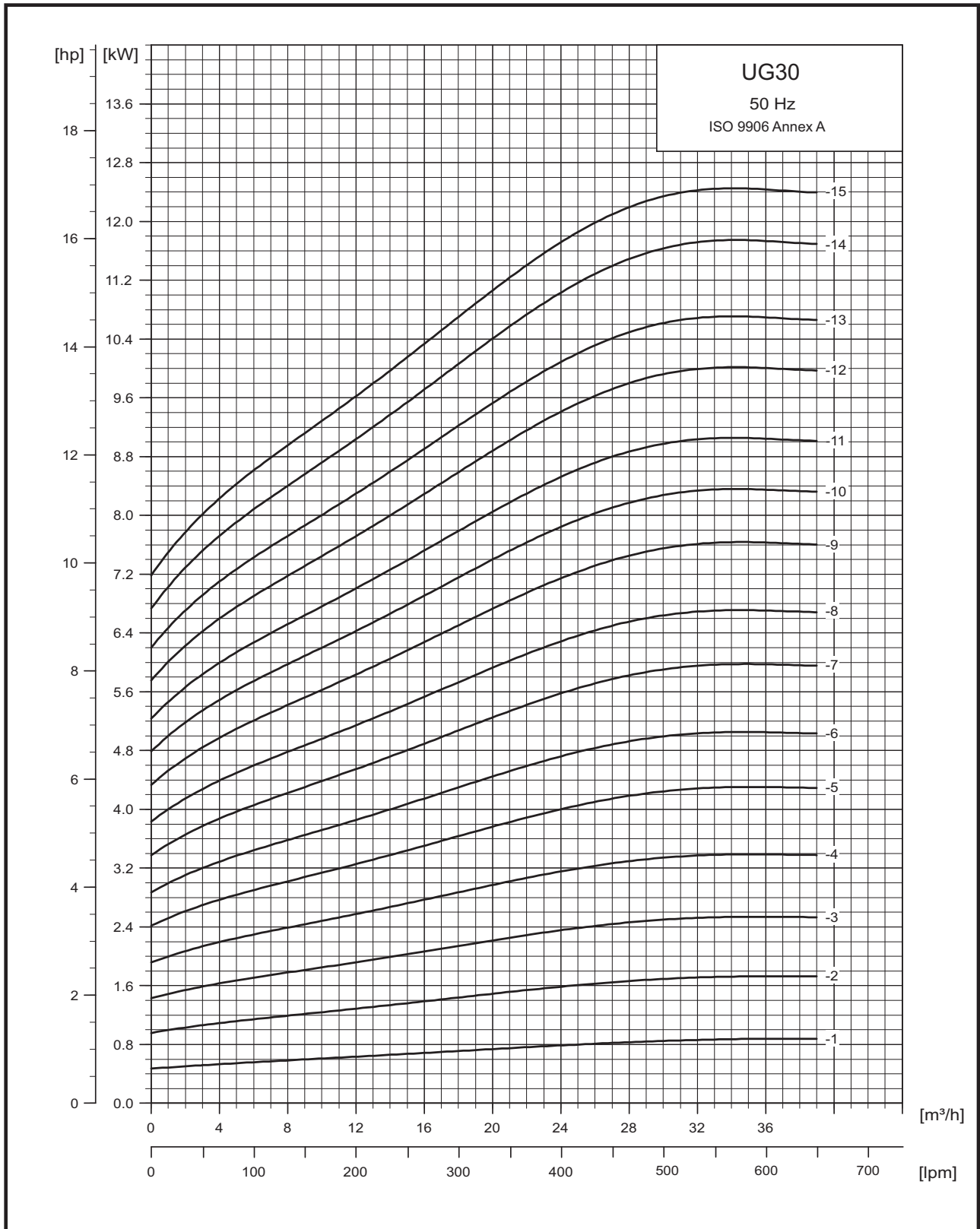

# UG30 - Leistungskurve

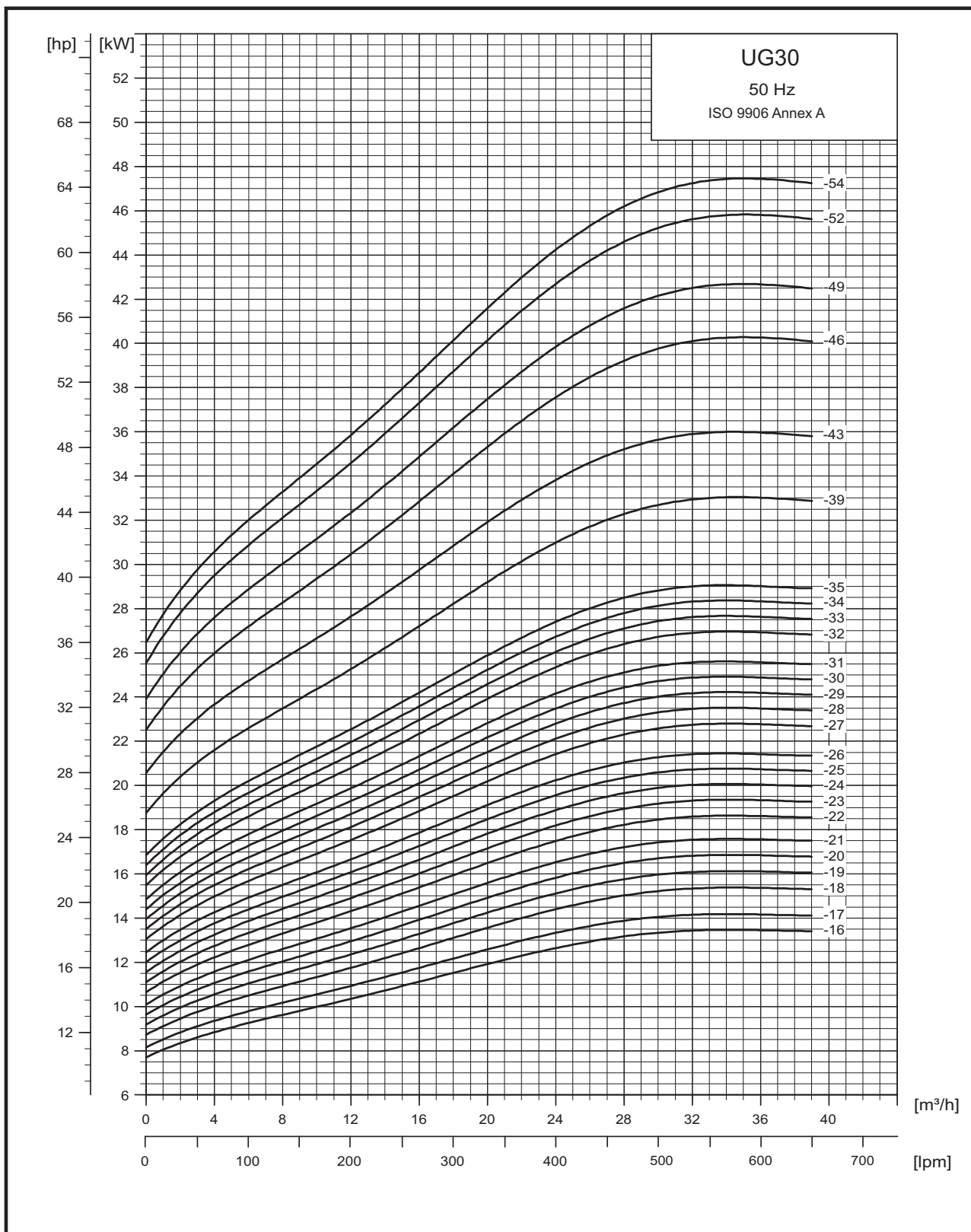

# UG46 - Kennlinien

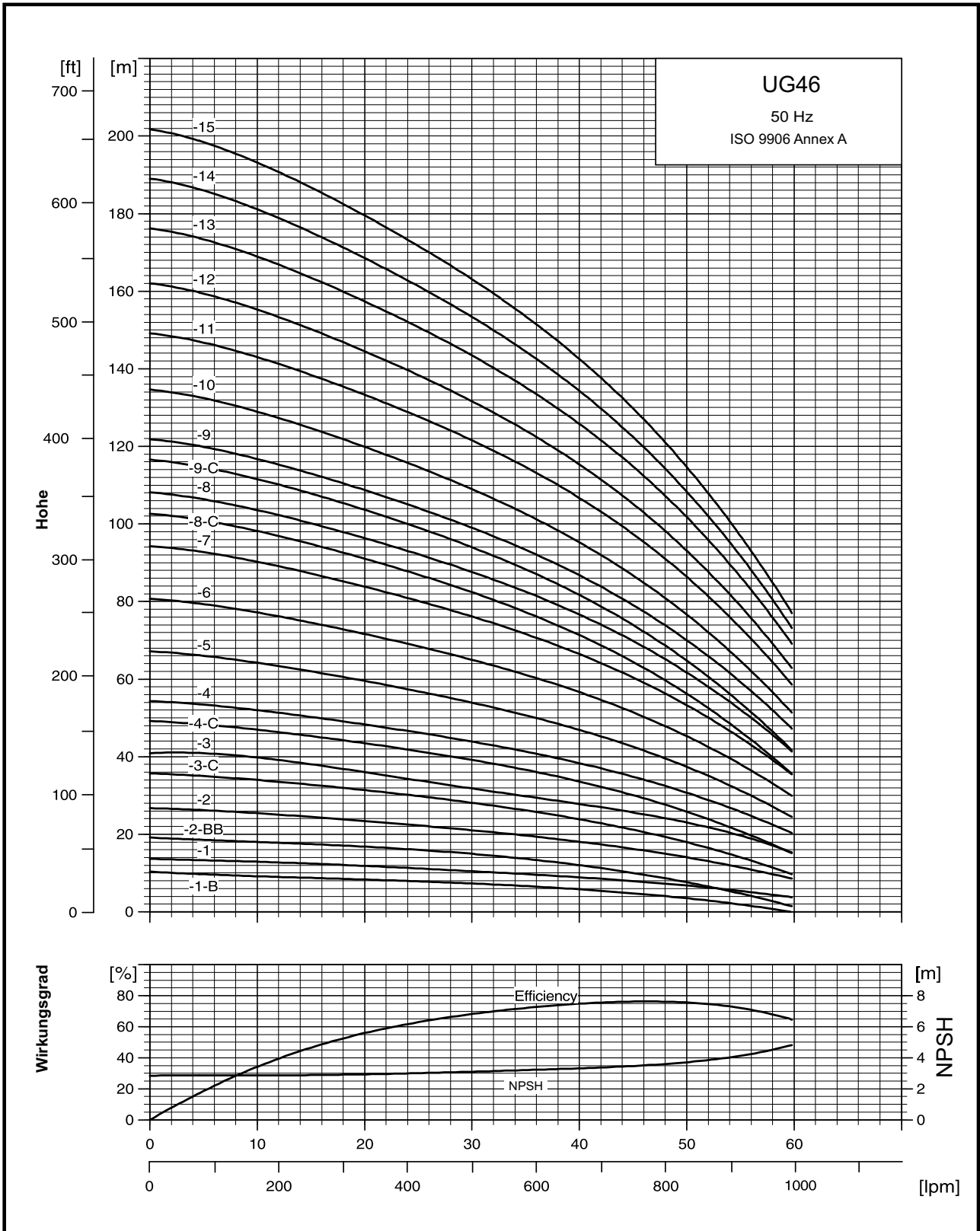

# UG46 - Kennlinien

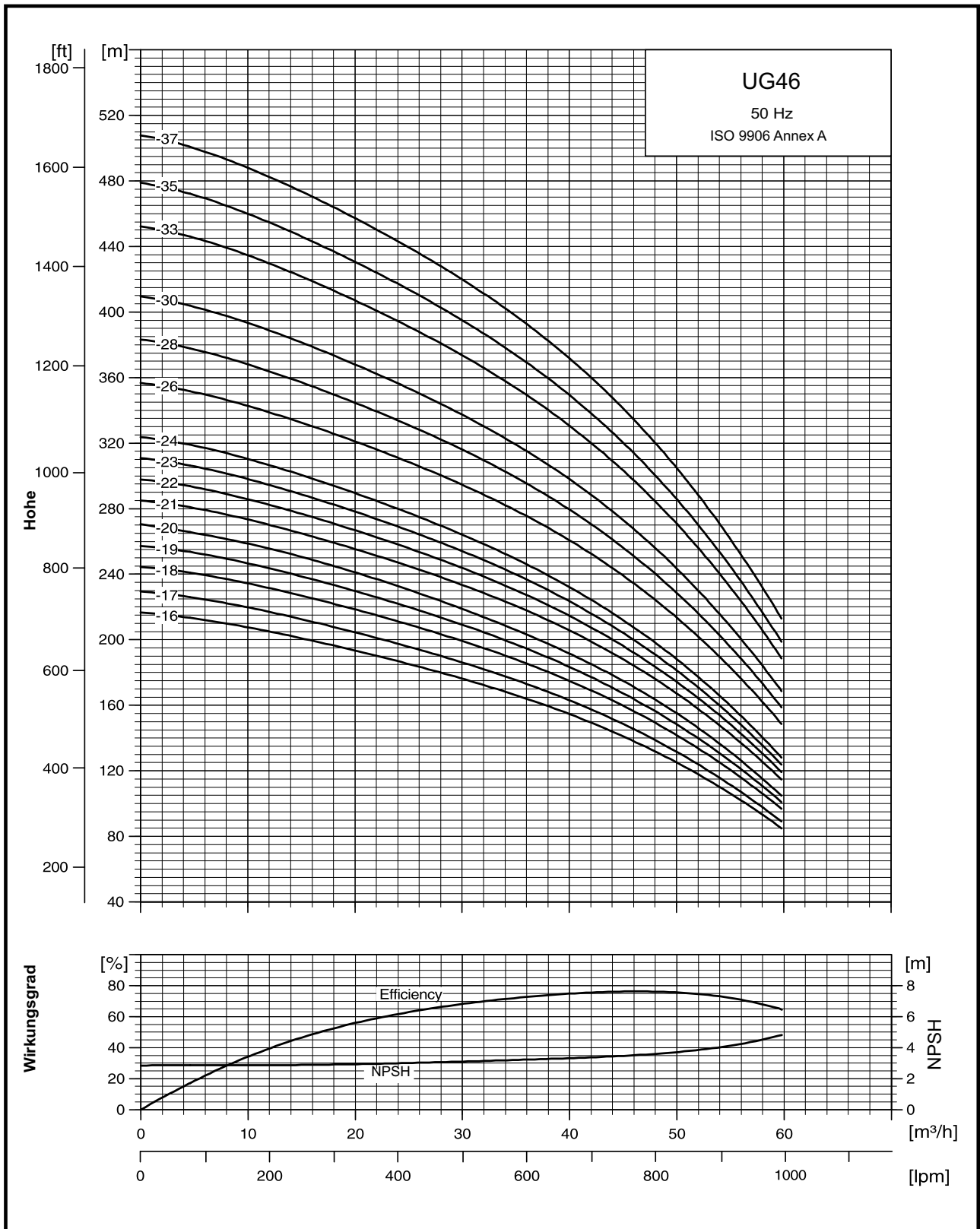

# UG46 - Technische Informationen

## Dimension und Gewicht

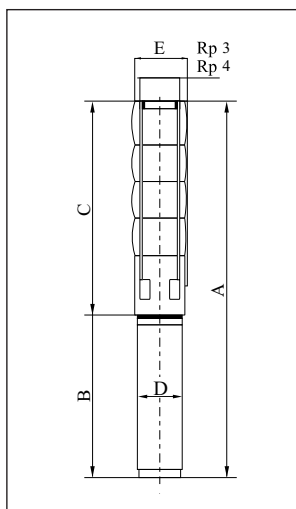

Pumpentyp	Motor		Dimensionen (mm)							Netto Gewicht (kg)		
	Typ UGM.... (inch/HP)	Power (kW/HP)	C	B		A		D	E*	E**	1x230V	3x230V 3x400V
				1x230V	3x230V 3x400V	1x230V	3x230V 3x400V					
UG46-1-B	UGM4/1.5	1.1 / 1.5	367	512	477	879	844	96	146		23.5	23
UG46-1	UGM4/3	2.2 / 3	367	657	637	1024	1004	96	146		34	30
UG46-2-BB	UGM4/3	2.2 / 3	480	657	637	1137	1117	96	146		36	31.9
UG46-2	UGM4/4	3 / 4	496		677		1173	96	146			35.2
UG46-3-C	UGM4/5.5	4 / 5.5	609		737		1346	96	146			40.5
UG46-3	UGM4/7.5	5.5 / 7.5	609		877		1486	96	146			47.8
UG46-4-C	UGM4/7.5	5.5 / 7.5	722		877		1599	96	146			50
UG46-4	UGM4/10	7.5 / 10	706		1017		1723	96	-			61.3
UG46-4	UGM6/10	7.5 / 10	722		706		1428	144	-			63.8
UG46-5	UGM6/10	7.5 / 10	835		706		1541	144	149	152		66
UG46-6	UGM6/12.5	9.2 / 12.5	948		736		1684	144	149	152		70.1
UG46-7	UGM6/15	11 / 15	1061		776		1837	144	149	152		80.2
UG46-8-C	UGM6/15	11 / 15	1174		776		1950	144	149	152		82.5
UG46-8	UGM6/17.5	13 / 17.5	1174		826		2000	144	149	152		88
UG46-9-C	UGM6/17.5	13 / 17.5	1287		826		2113	144	149	152		90.4
UG46-10	UGM6/20	15 / 20	1400		866		2266	144	149	152		96
UG46-11	UGM6/25	18.5 / 25	1513		921		2434	144	149	152		104.1
UG46-12	UGM6/25	18.5 / 25	1626		921		2547	144	149	152		106.4
UG46-13	UGM6/30	22 / 30	1739		996		2735	144	149	152		118.4
UG46-14	UGM6/30	22 / 30	1852		996		2848	144	149	152		120.6
UG46-15	UGM6/30	22 / 30	1965		996		2961	144	149	152		123
UG46-16	UGM6/35	26 / 35	2078		1056		3134	144	149	152		133.9
UG46-17	UGM6/35	26 / 35	2191		1056		3247	144	149	152		136.4
UG46-18	UGM6/40	30 / 40	2304		1176		3480	144	149	152		145.4
UG46-19	UGM6/40	30 / 40	2417		1176		3593	144	149	152		147.9
UG46-20	UGM6/40	30 / 40	2530		1176		3706	144	149	152		149.9
UG46-21	UGM8/50	37 / 50	2643		1010		3653	190	149	152		188.2
UG46-22	UGM8/50	37 / 50	2756		1010		3766	190	149	152		190.8
UG46-23	UGM8/50	37 / 50	2869		1010		3879	190	149	152		192.7
UG46-24	UGM8/50	37 / 50	2982		1010		3992	190	149	152		195.3
UG46-26	UGM8/60	45 / 60	3570		1062		4632	190	-	-		-
UG46-28	UGM8/60	45 / 60	3810		1062		4872	190	-	-		-
UG46-30	UGM8/60	45 / 60	4050		1062		5112	190	-	-		-
UG46-33	UGM8/75	55 / 75	4410		1168		5578	190	-	-		-
UG46-35	UGM8/75	55 / 75	4650		1168		5818	190	-	-		-
UG46-37	UGM8/90	67 / 90	4890		1262		6152	192	-	-		-

• Pumpe mit äusserem Stahlrohr .

\* Maximum Durchmesser von Pumpe mit Motor und einem Kabel

\*\* Maximum Durchmesser von Pumpe mit Motor und 2 Kabeln

- Auf Anfrage

# UG46 - Leistungskurve

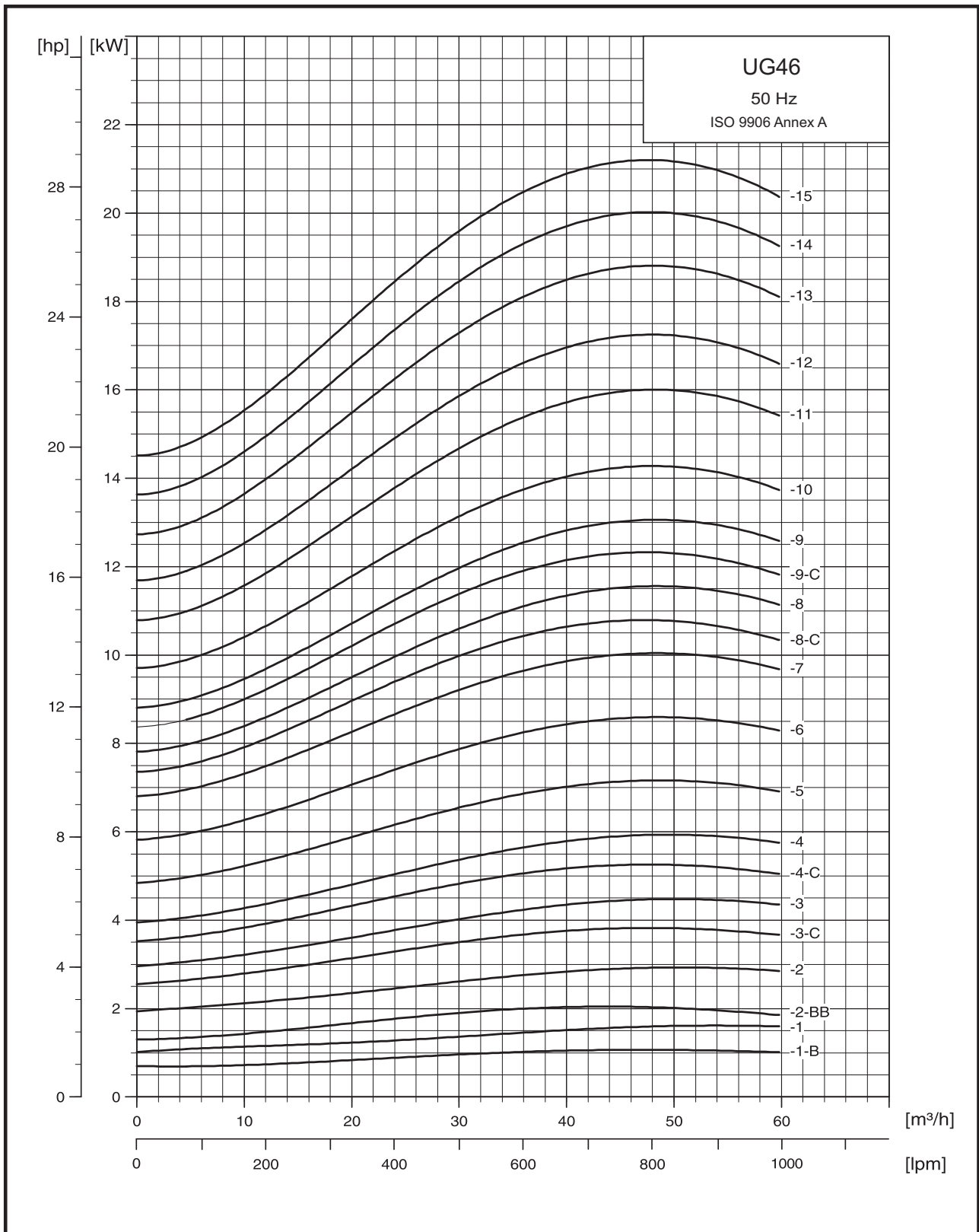

# UG46 - Leistungskurve

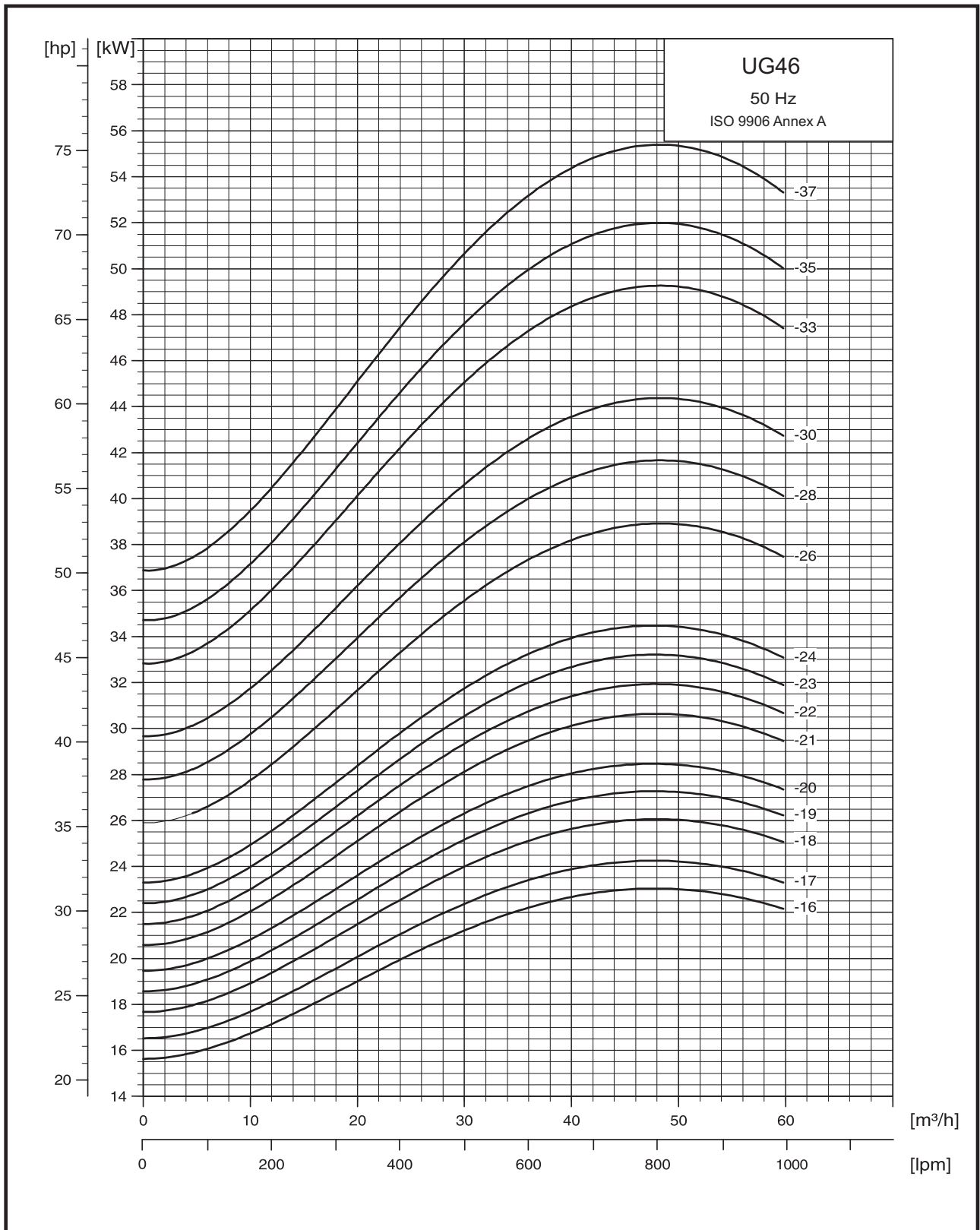



# UG60 - Kennlinien

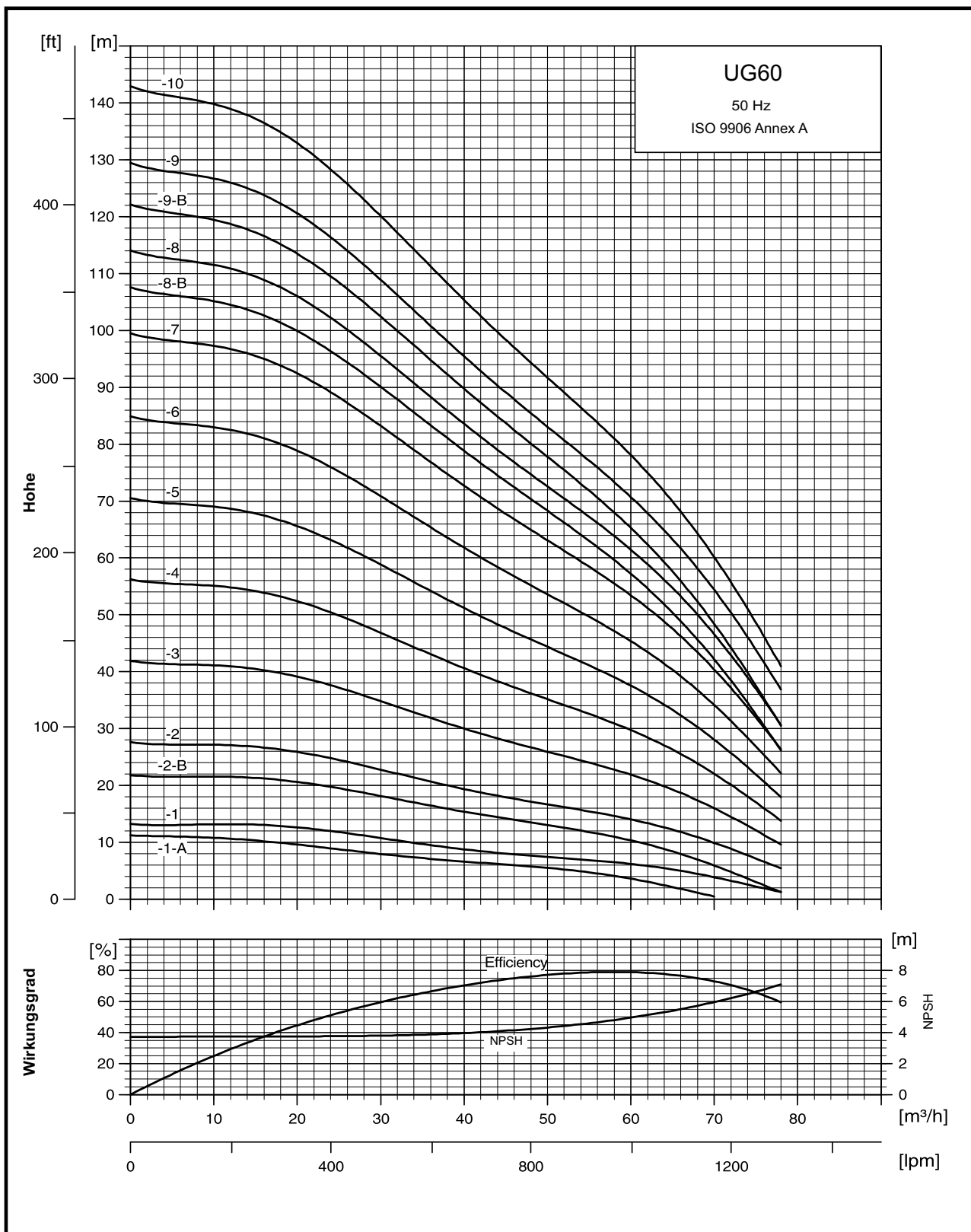

# UG60 - Kennlinien

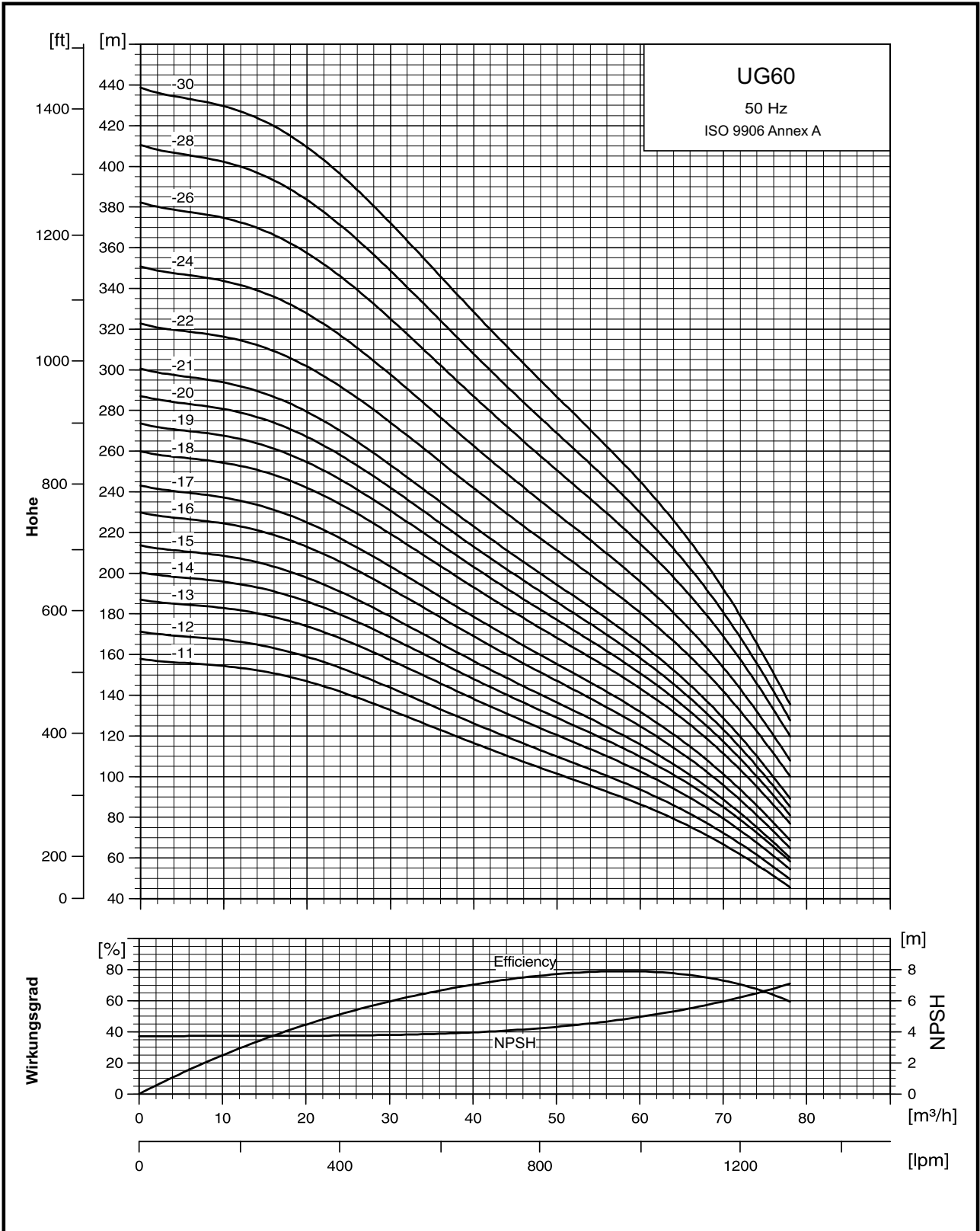

# UG60 - Technische Informationen

## Dimension und Gewicht

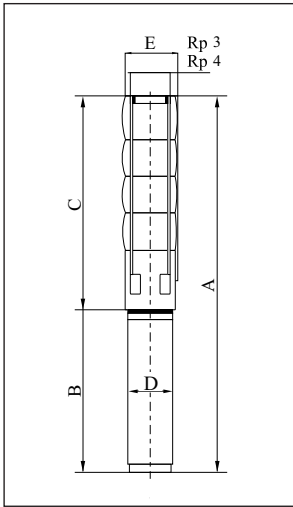

Pumpentyp	Motor		Dimensionen (mm)							Netto Gewicht (kg)		
	Typ UGM.... (inch/HP)	Power (KW/HP)	C	B		A		D	E*	E**	1x230V	3x230V 3x400V
				1x230V	3x230V 3x400V	1x230V	3x230V 3x400V					
UG60-1-A	UGM4/2	1.5 / 2	367	579	599	946	966	96	146		23	29
UG60-1	UGM4/3	2.2 / 3	383	657	637	1040	1020	96	146			31
UG60-2-B	UGM4/4	3 / 4	480		677		1157	96	146			34
UG60-2	UGM4/5.5	4 / 5.5	496		737		1233	96	146			37
UG60-3	UGM4/7.5	5.5 / 7.5	593		877		1470	96	146			47.8
UG60-4	UGM4/10	7.5 / 10	722		1017		1739	96	152	-		54.7
UG60-3	UGM6/7.5	5.5 / 7.5	609		676		1285	144	-	-		59.5
UG60-4	UGM6/10	7.5 / 10	702		706		1408	144	-	-		63.7
UG60-5	UGM6/12.5	9.2 / 12.5	835		736		1571	144	149	152		67.8
UG60-6	UGM6/15	11 / 15	948		776		1724	144	149	152		78
UG60-7	UGM6/17.5	13 / 17.5	1061		826		1887	144	149	152		85.8
UG60-8-B	UGM6/17.5	13 / 17.5	1174		826		2000	144	149	152		88
UG60-8	UGM6/20	15 / 20	1174		866		2040	144	149	152		91.5
UG60-9-B	UGM6/20	15 / 20	1287		866		2153	144	149	152		93.7
UG60-9	UGM6/25	18.5 / 25	1287		921		2208	144	149	152		99.5
UG60-10	UGM6/25	18.5 / 25	1400		921		2321	144	149	152		101.8
UG60-11	UGM6/30	22 / 30	1513		996		2509	144	149	152		114
UG60-12	UGM6/30	22 / 30	1626		996		2622	144	149	152		116.2
UG60-13	UGM6/35	26 / 35	1739		1056		2795	144	149	152		127.3
UG60-14	UGM6/35	26 / 35	1852		1056		2908	144	149	152		129.5
UG60-15	UGM6/35	26 / 35	1965		1056		3021	144	149	152		131
UG60-16	UGM6/40	30 / 40	2078		1176		3254	144	149	152		141
UG60-17	UGM6/40	30 / 40	2191		1176		3367	144	149	152		143.4
UG60-18	UGM8/50	37 / 50	2304		1010		3314	190	149	152		181.7
UG60-19	UGM8/50	37 / 50	2417		1010		3427	190	149	152		184
UG60-20	UGM8/50	37 / 50	2530		1010		3540	190	149	152		186.2
UG60-21	UGM8/50	37 / 50	2643		1010		3653	190	-	-		188.5
UG60-22	UGM8/60	45 / 60	2784		1062		3846	190	-	-		-
UG60-24	UGM8/60	45 / 60	3010		1062		4072	190	-	-		-
UG60-26	UGM8/75	55 / 75	3236		1168		4404	190	-	-		-
UG60-28	UGM8/75	55 / 75	3462		1168		4630	190	-	-		-
UG60-30	UGM8/75	55 / 75	3688		1168		4856	190	-	-		-

\* Maximum Durchmesser von Pumpe mit Motor und einem Kabel

\*\* Maximum Durchmesser von Pumpe mit Motor und 2 Kabeln

- Auf Anfrage

# UG60 - Leistungskurve

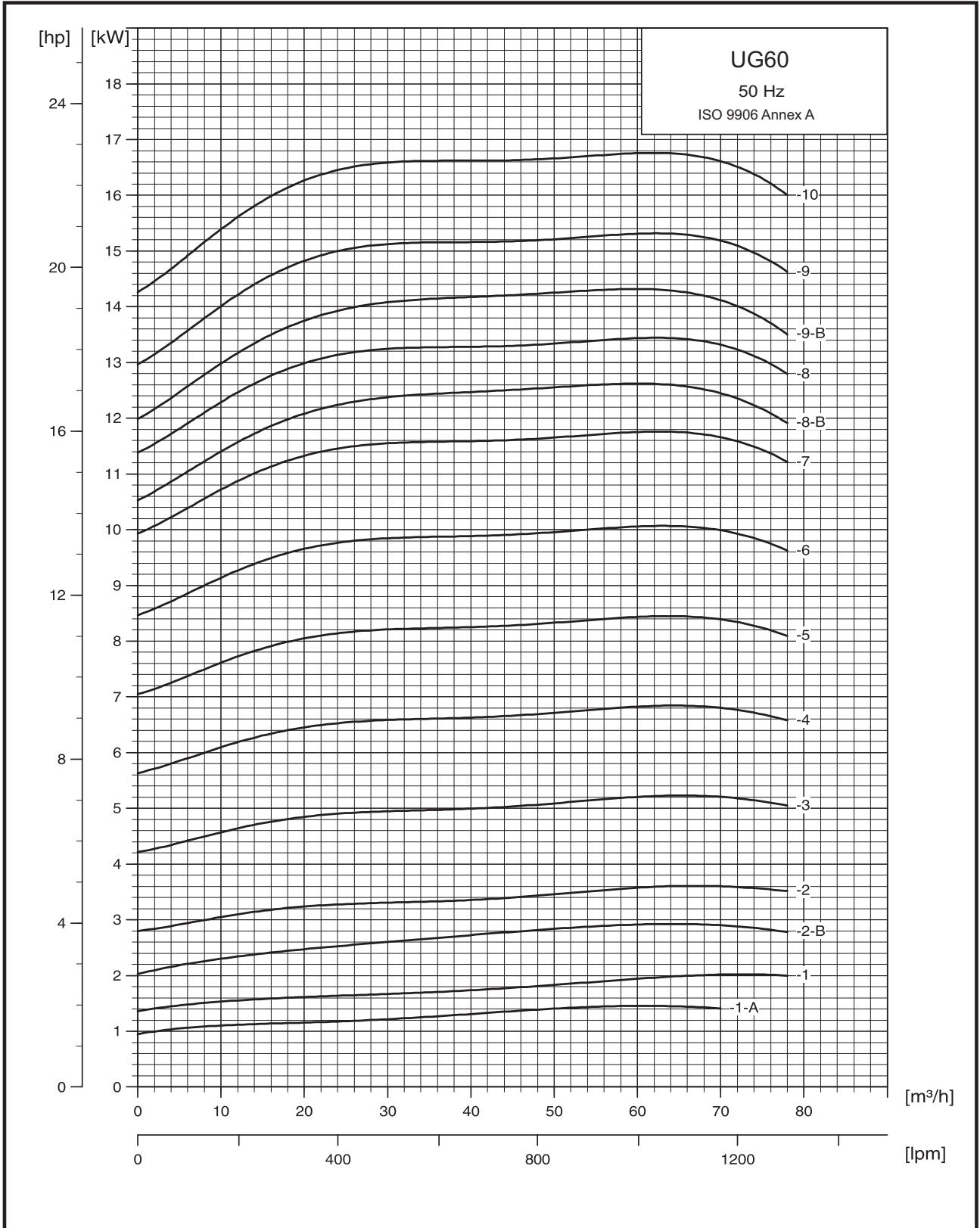

# UG60 - Leistungskurve

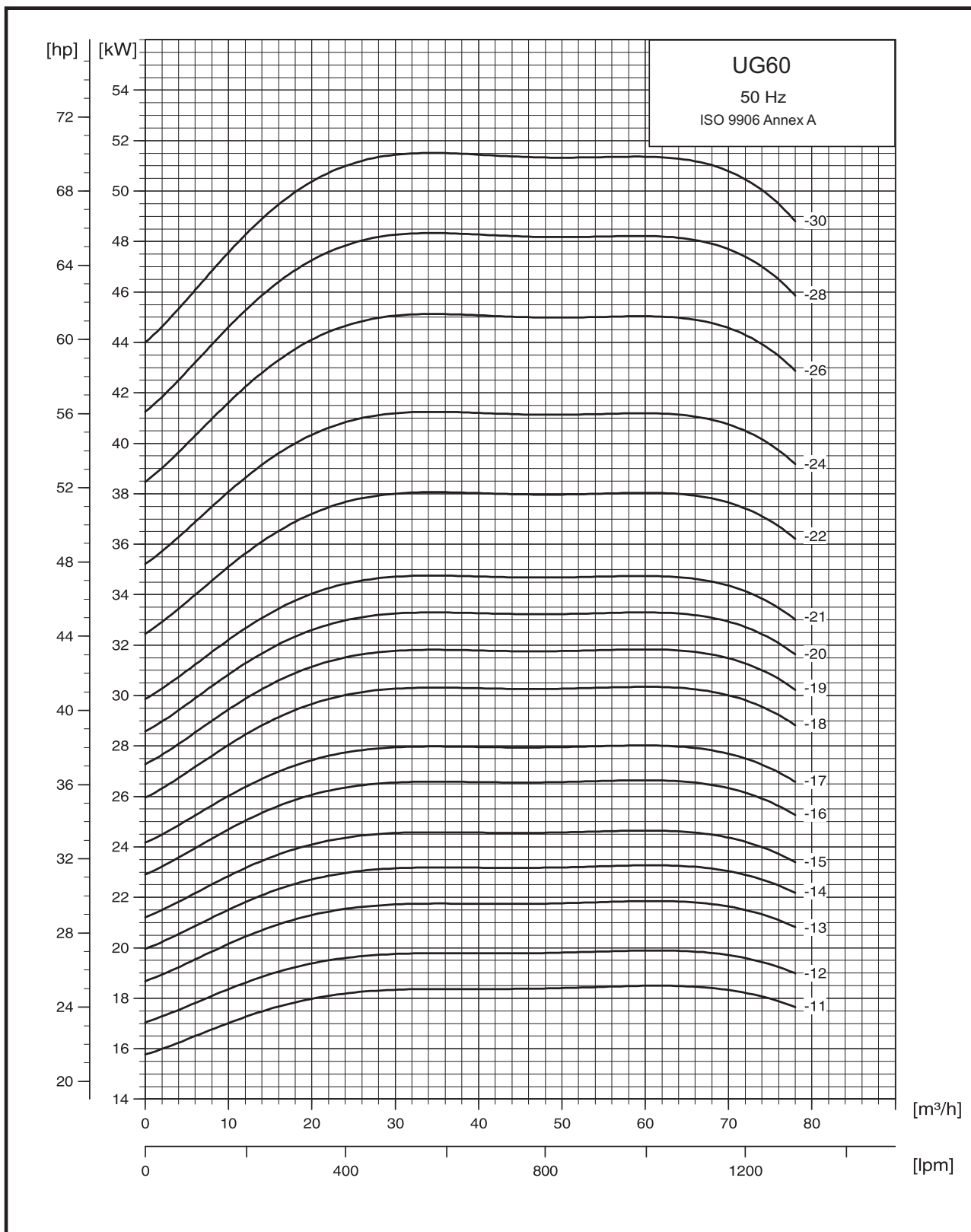

# UG77 - Kennlinien

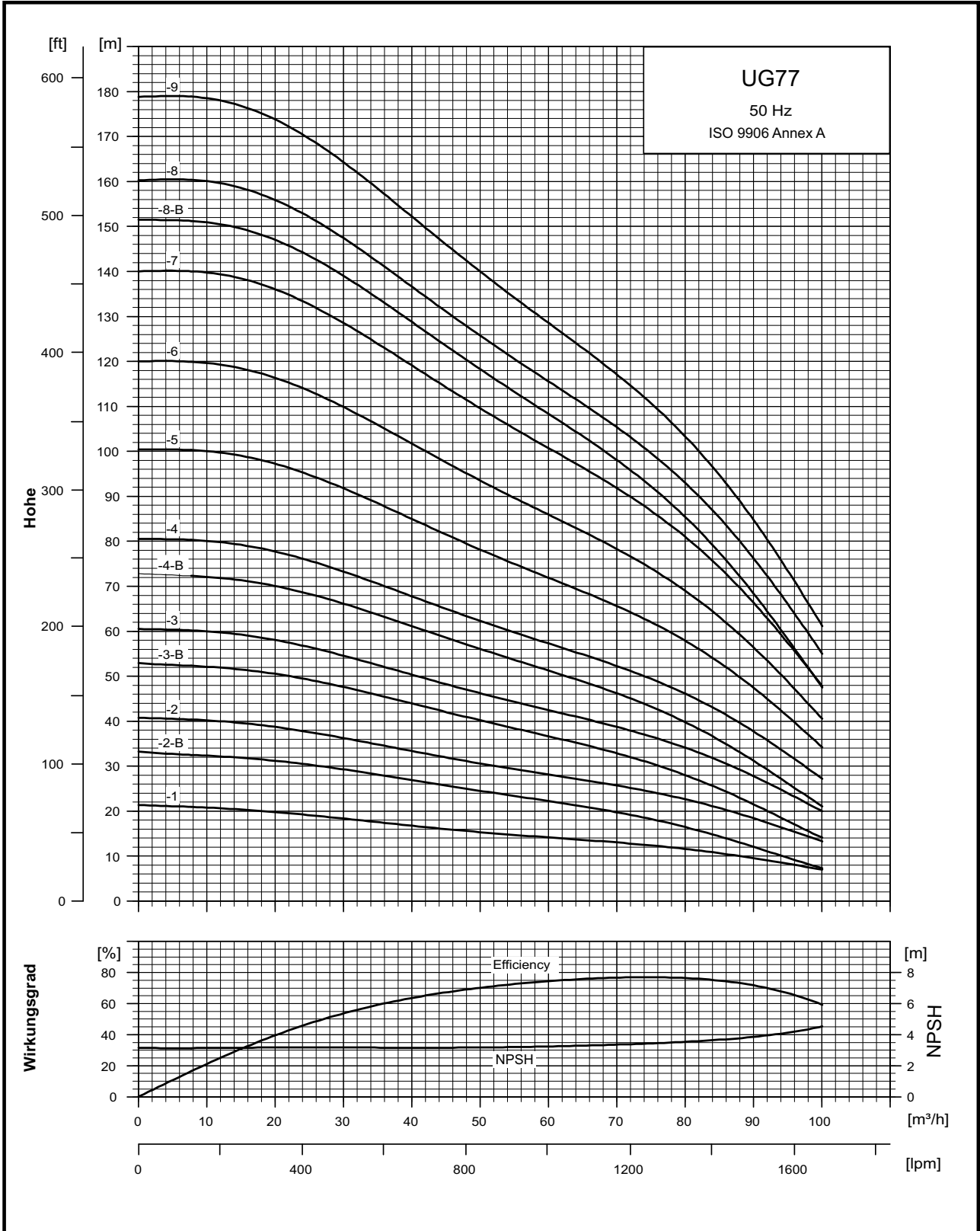

# UG77 - Kennlinien

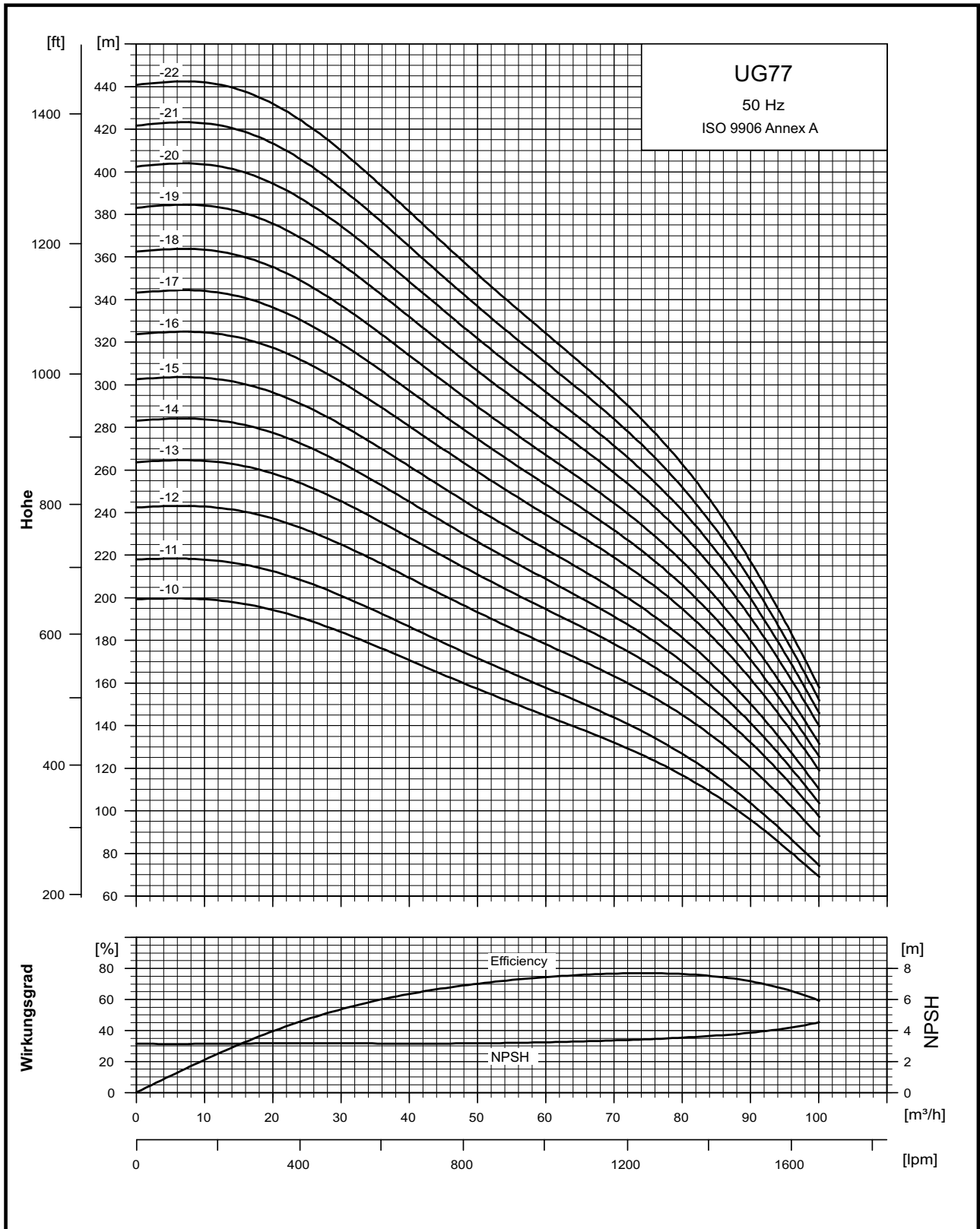

# UG77 - Technische Informationen

## Dimension und Gewicht

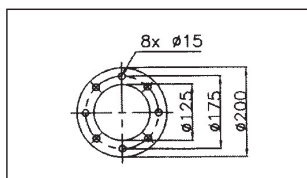
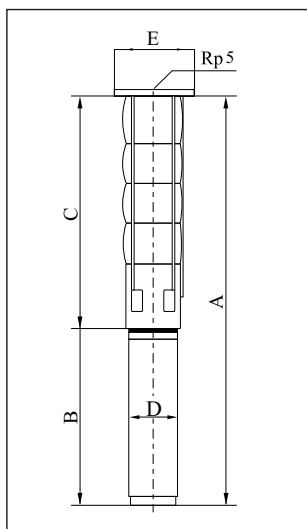

Pumpentyp	Motor		Dimensionen (mm)										Netto Gewicht (kg)
	Typ UGM.... (inch/HP)	Power (KW/HP)	5" Anschluss (RP,NPT)				5" Flansch				B	D	
			A	C	E*	E**	A	C	E*	E**			
UG77-1	UGM6/7.5	5.5 / 7.5	1294	618	178	186	1294	618	200	200	676	144	73
UG77-2-B	UGM6/7.5	5.5 / 7.5	1422	746	178	186	1422	746	200	200	676	144	76.7
UG77-2	UGM6/10	7.5 / 10	1452	746	178	186	1452	746	200	200	706	144	78.7
UG77-3-B	UGM6/12.5	9.2 / 12.5	1610	874	178	186	1610	874	200	200	736	144	84.1
UG77-3	UGM6/15	11 / 15	1650	874	178	186	1650	874	200	200	776	144	92
UG77-4-B	UGM6/17.5	13 / 17.5	1829	1003	178	186	1829	1003	200	200	826	144	101
UG77-4	UGM6/20	15 / 20	1869	1003	178	186	1869	1003	200	200	866	144	104.5
UG77-5	UGM6/25	18.5 / 25	2052	1131	178	186	2052	1131	200	200	921	144	114
UG77-6	UGM6/30	22 / 30	2255	1259	178	186	2255	1259	200	200	996	144	127.2
UG77-7	UGM6/35	26 / 35	2343	1287	178	186	2343	1287	200	200	1056	144	139.6
UG77-8-B	UGM6/35	26 / 35	2571	1515	178	186	2571	1515	200	200	1056	144	143.2
UG77-8	UGM6/40	30 / 40	2691	1515	178	186	2691	1515	200	200	1176	144	150.2
UG77-9	UGM6/40	30 / 40	2820	1644	178	186	2820	1644	200	200	1176	144	153.8
UG77-10	UGM8/50	37 / 50	2782	1772	178	186	2782	1772	200	200	1010	190	193.4
UG77-11	UGM8/50	37 / 50	2910	1900	178	186	2910	1900	200	200	1010	190	197
UG77-12	UGM8/60	45 / 60	3101	2039	200	204	3101	2039	209	209	1062	190	202
UG77-13	UGM8/75	55 / 75	3336	2168	200	204	3336	2168	209	209	1168	190	224.6
UG77-14	UGM8/75	55 / 75	3464	2296	200	204					1168	190	228.2
UG77-15	UGM8/75	55 / 75	3592	2424	200	204					1168	190	231.8
UG77-16	UGM8/90	67 / 90	3814	2552	200	204					1262	192	242.4
UG77-17	UGM8/90	67 / 90	3944	2682	200	204					1262	192	246
UG77-18	UGM8/90	67 / 90	4071	2809	200	204					1262	192	249.6
UG77-19	UGM8/100	75 / 100	4263	2939	200	204					1324	192	275.2
UG77-20	UGM8/100	75 / 100	4389	3065	200	204					1324	192	278.8
UG77-21	UGM8/100	75 / 100	4520	3196	200	204					1324	192	282.4
UG77-22	UGM8/125	92 / 125	4793	3324	200	204					1469	192	317

\* Maximum Durchmesser von Pumpe mit Motor und einem Kabel

\*\* Maximum Durchmesser von Pumpe mit Motor und 2 Kabeln



# UG77 - Leistungskurve

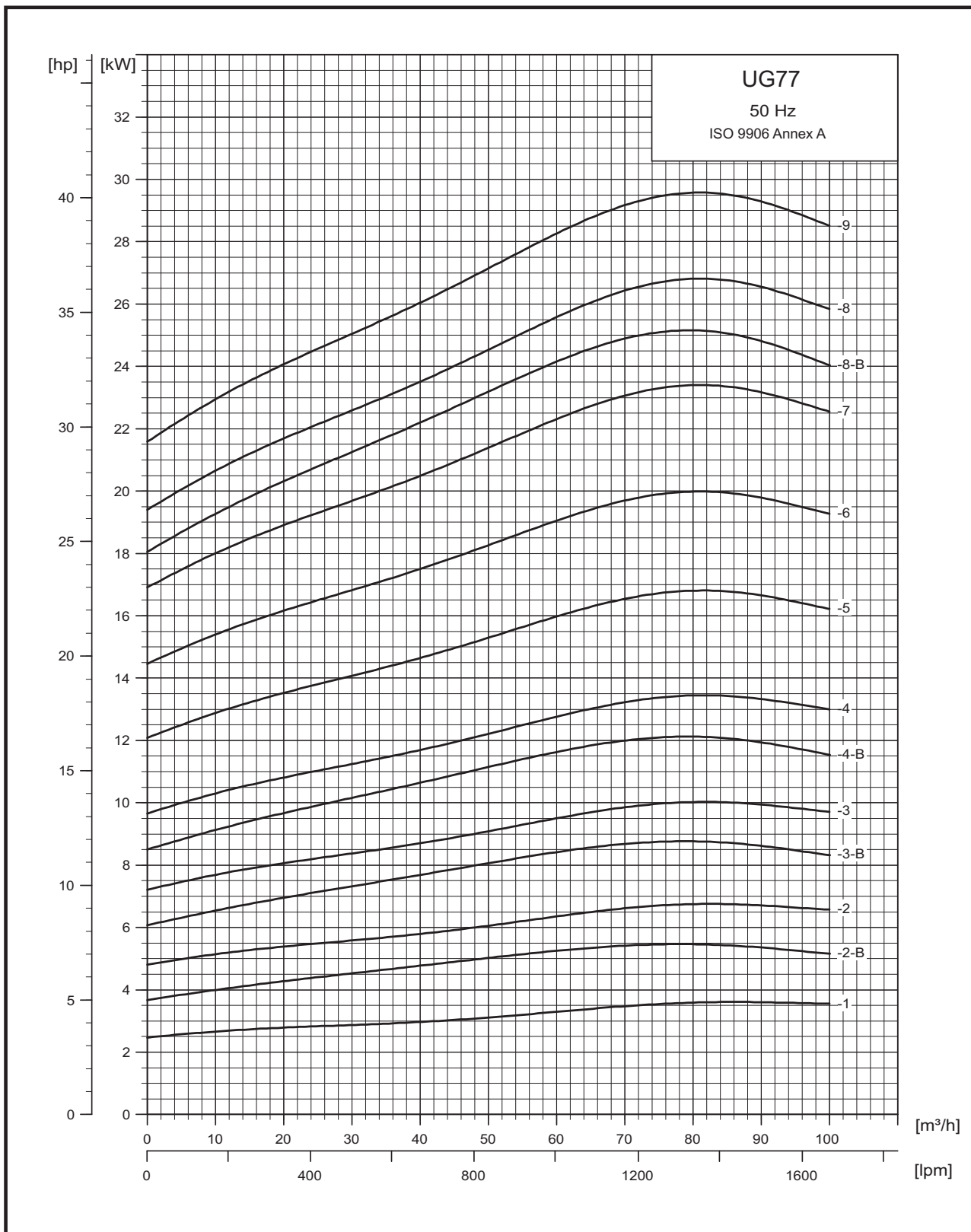

# UG77 - Leistungskurve

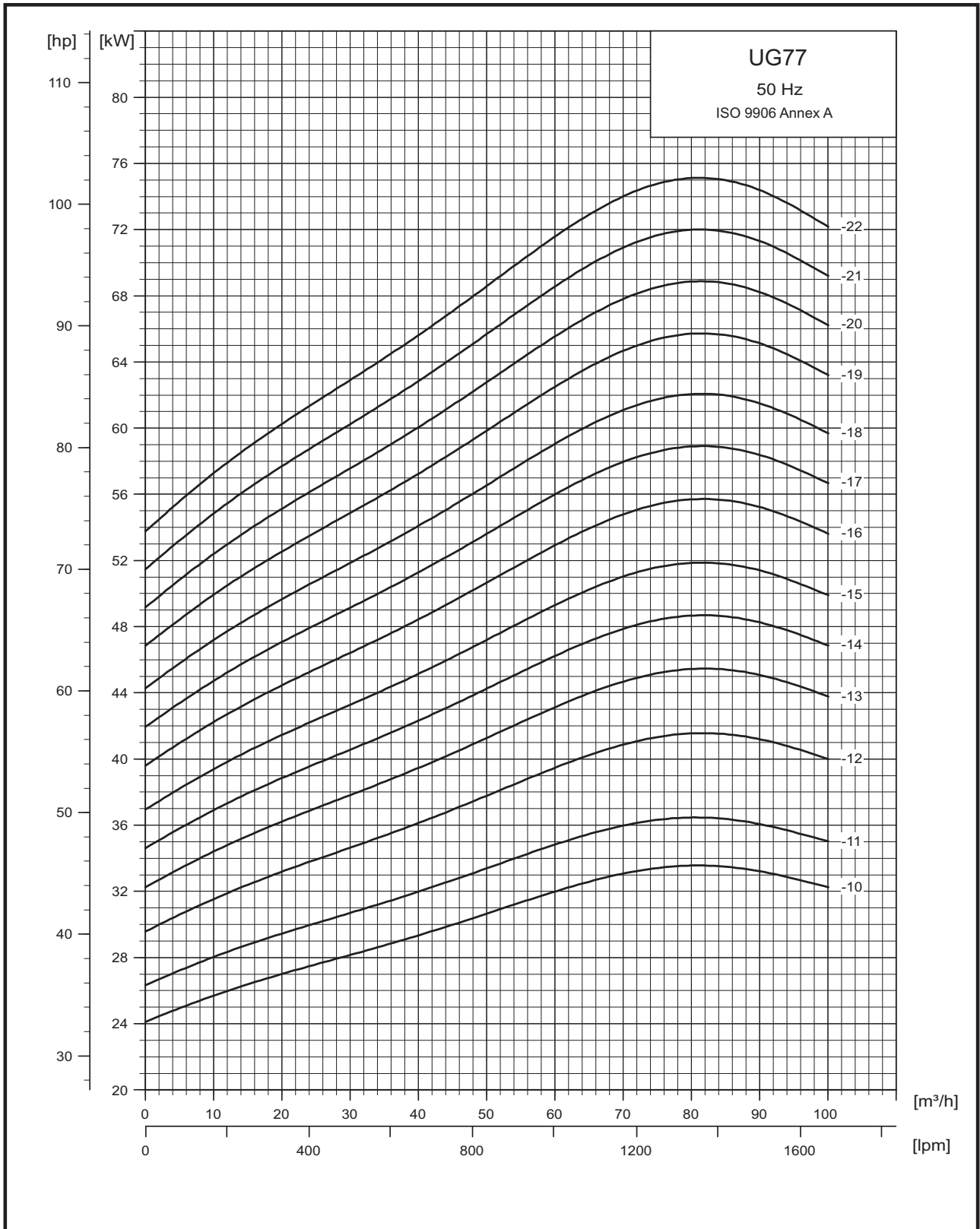

# UG95 - Kennlinien

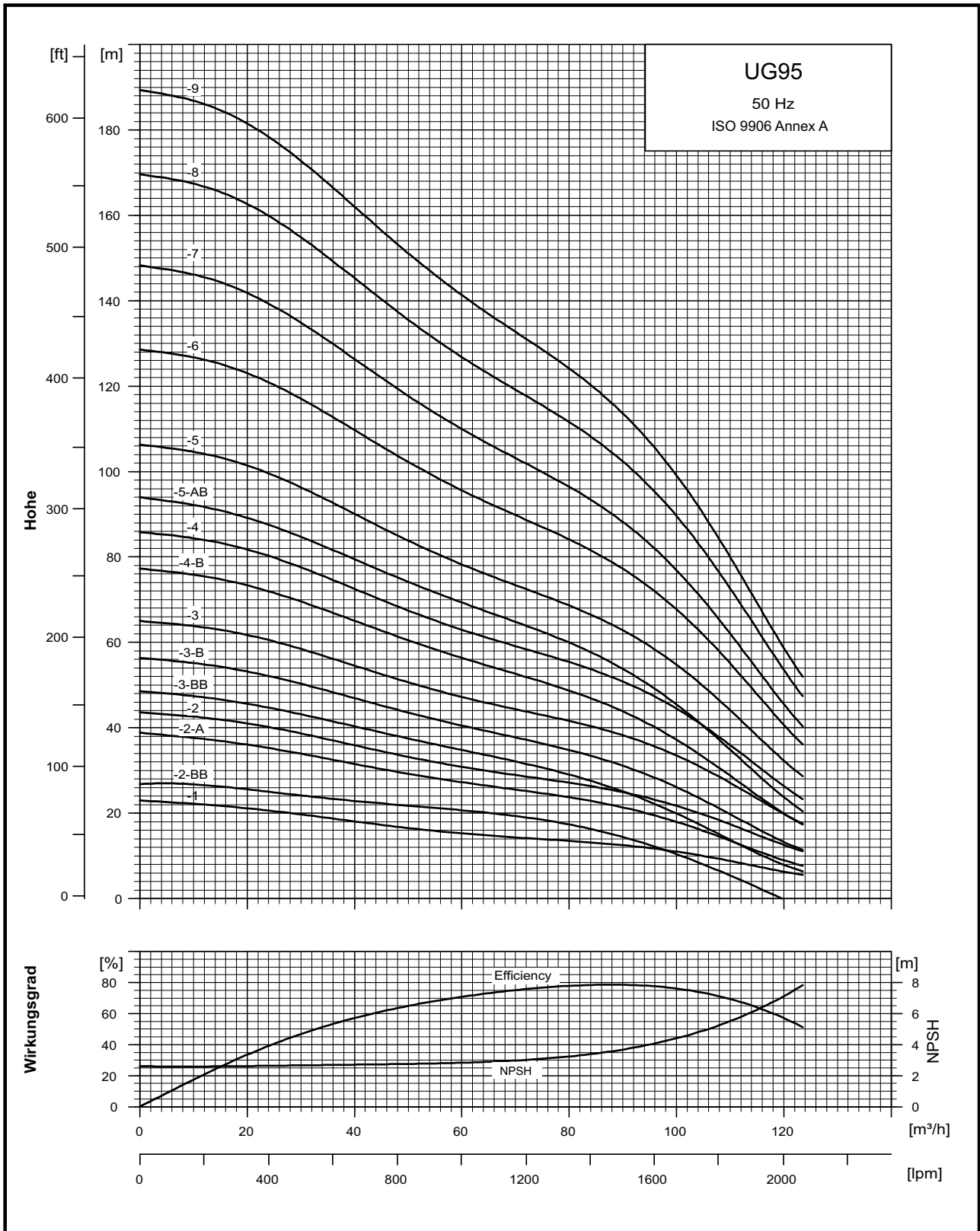

# UG95 - Kennlinien

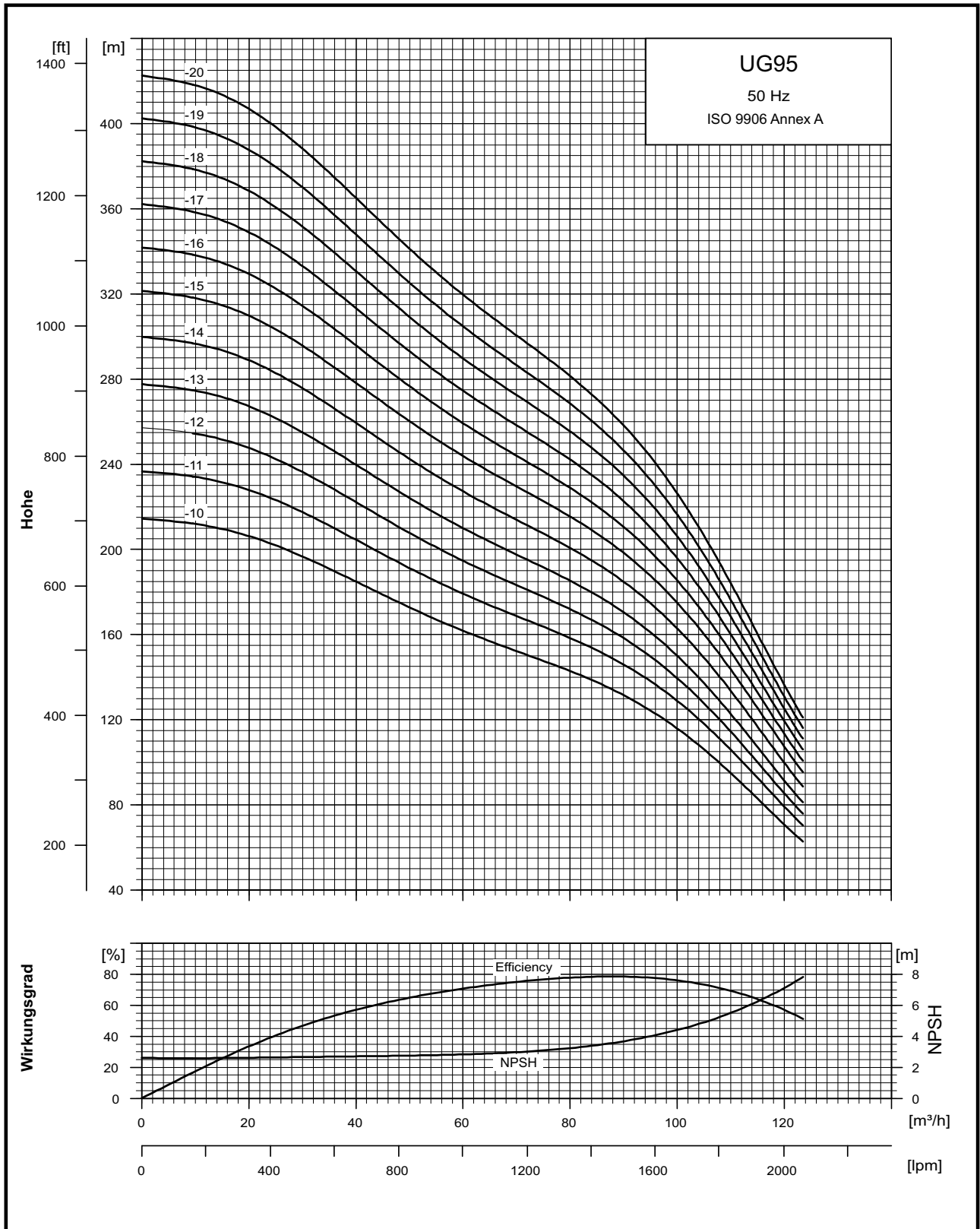

# UG95 - Technische Informationen

## Dimension und Gewicht

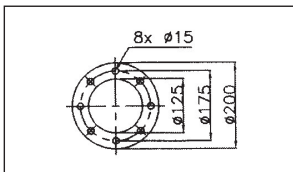
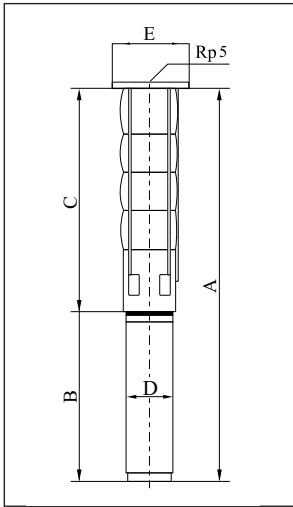

Pumpentyp	Motor		Dimensionen (mm)										Netto Gewicht (kg)
	Typ UGM.... (inch/HP)	Power (KW/HP)	5" Anschluss (RP,NPT)				5" Flansch				B	D	
			A	C	E*	E**	A	C	E*	E**			
UG95-1	UGM6/7.5	5.5/7.5	1294	618	178	186	1294	618	200	200	676	144	73
UG95-2-BB	UGM6/7.5	5.5/7.5	1422	746	178	186	1422	746	200	200	676	144	76.7
UG96-2-A	UGM6/10	7.5/10	1452	746	178	186	1452	746	200	200	706	144	78.7
UG95-2	UGM6/12.5	9.2/12.5	1482	746	178	186	1482	746	200	200	736	144	80.2
UG95-3-BB	UGM6/12.5	9.2/12.5	1610	874	178	186	1610	874	200	200	736	144	84
UG95-3-B	UGM6/15	11 / 15	1650	874	178	186	1650	874	200	200	776	144	92
UG95-3	UGM6/17.5	13/17.5	1700	874	178	186	1700	874	200	200	826	144	97.5
UG95-4-B	UGM6/20	15/20	1869	1003	178	186	1869	1003	200	200	866	144	104.5
UG95-4	UGM6/25	18.5/25	1924	1003	178	186	1924	1003	200	200	921	144	110.3
UG95-5-AB	UGM6/30	22/30	2127	1131	178	186	2127	1131	200	200	996	144	123.7
UG95-5	UGM6/30	22/30	2127	1131	178	186	2127	1131	200	200	996	144	123.7
UG95-6	UGM6/35	26/35	2315	1259	178	186	2315	1259	200	200	1056	144	136
UG95-7	UGM6/40	30/40	2573	1397	178	186	2563	1387	200	200	1176	144	146.6
UG95-8	UGM8/50	37/50	2535	1525	178	186	2525	1515	200	200	1010	190	186.2
UG95-9	UGM8/60	45/60	2706	1644	178	186	2706	1644	200	200	1062	190	196.8
UG95-10	UGM8/60	45/60	2845	1783	196	204	2845	1783	205	205	1062	190	201.8
UG95-11	UGM8/75	55/75	3079	1911	196	204	3079	1911	205	205	1168	190	217.4
UG95-12	UGM8/75	55/75	3207	2039	196	204	3207	2039	205	205	1168	190	221
UG95-13	UGM8/75	55/75	3336	2168	196	204	3336	2168	205	205	1168	190	224.6
UG95-14	UGM8/90	67/90	3558	2296	196	204	3558	2296	205	205	1262	192	235.2
UG95-15	UGM8/100	75/100	3748	2424	196	204					1324	192	260.7
UG95-16	UGM8/100	75/100	3877	2553	196	204					1324	192	264.4
UG95-17	UGM8/100	75/100	4004	2680	196	204					1324	192	268
UG95-18	UGM8/125	92/125	4278	2809	196	204					1469	192	302.6
UG95-19	UGM8/125	92/125	4408	2939	196	204					1469	192	306.2
UG95-20	UGM8/125	92/125	4534	3065	196	204					1469	192	309.8

\* Maximum Durchmesser von Pumpe mit Motor und einem Kabel

\*\* Maximum Durchmesser von Pumpe mit Motor und 2 Kabeln

# UG95 - Leistungskurve

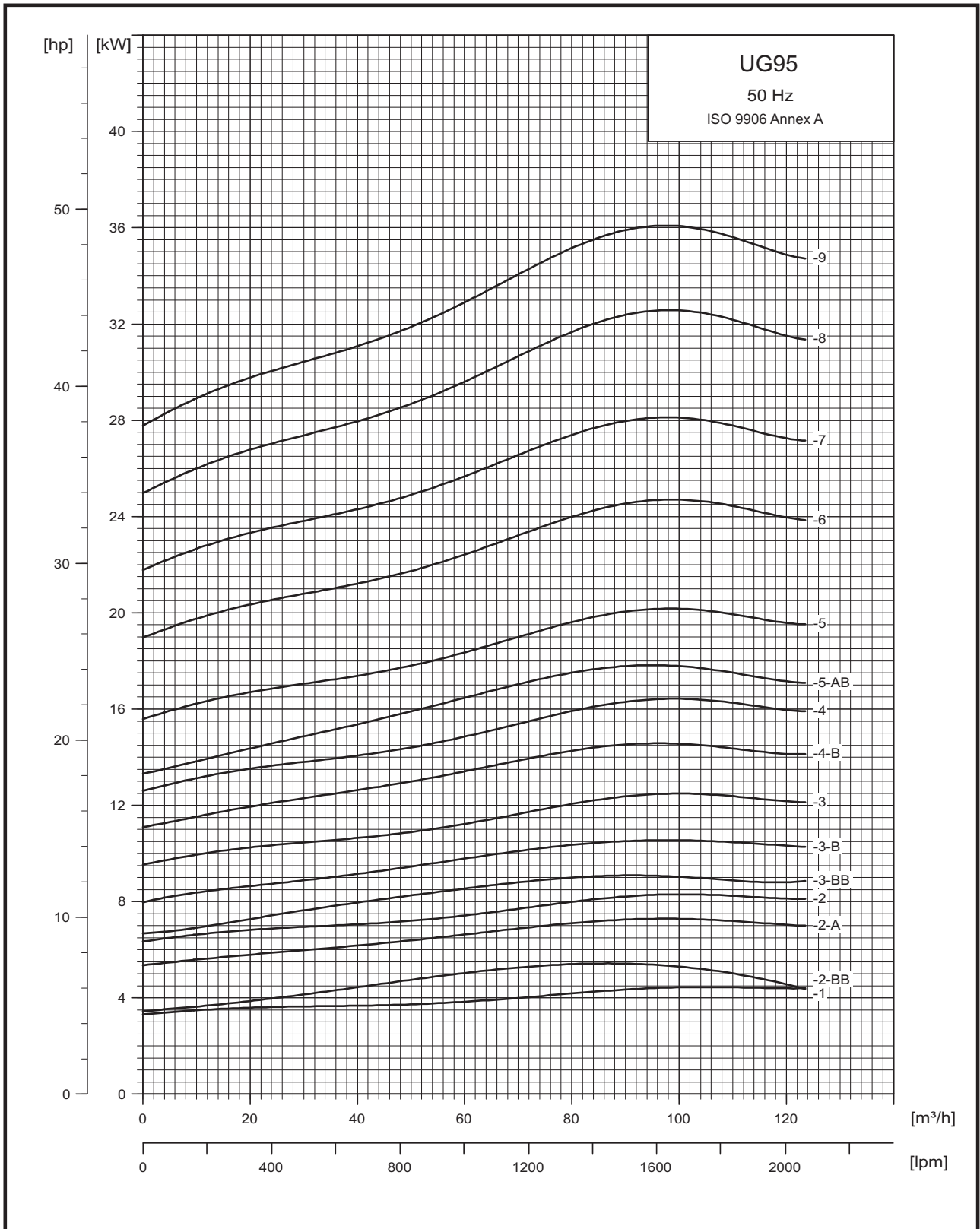

# UG95 - Leistungskurve

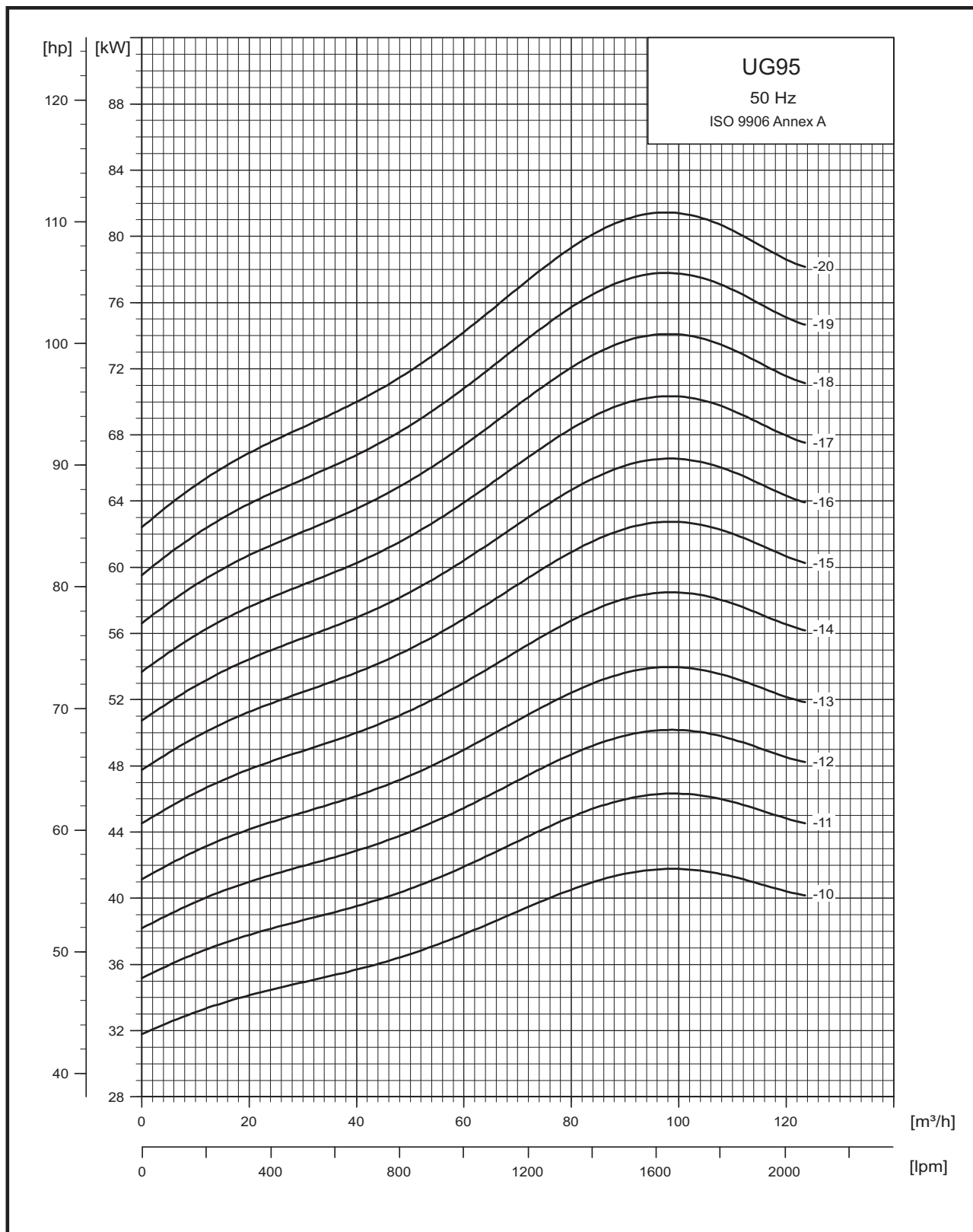

# UG125 - Kennlinien

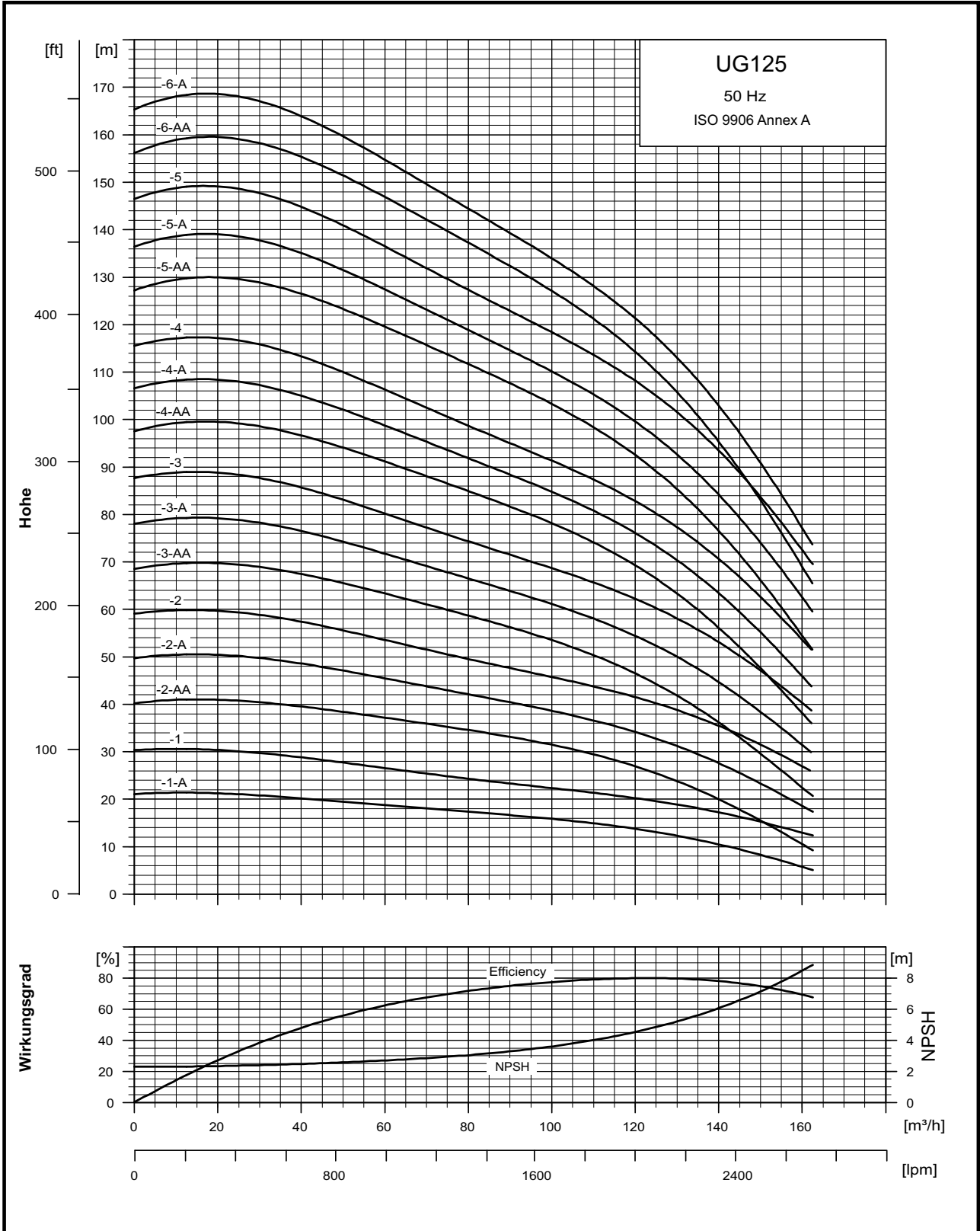



# UG125 - Kennlinien

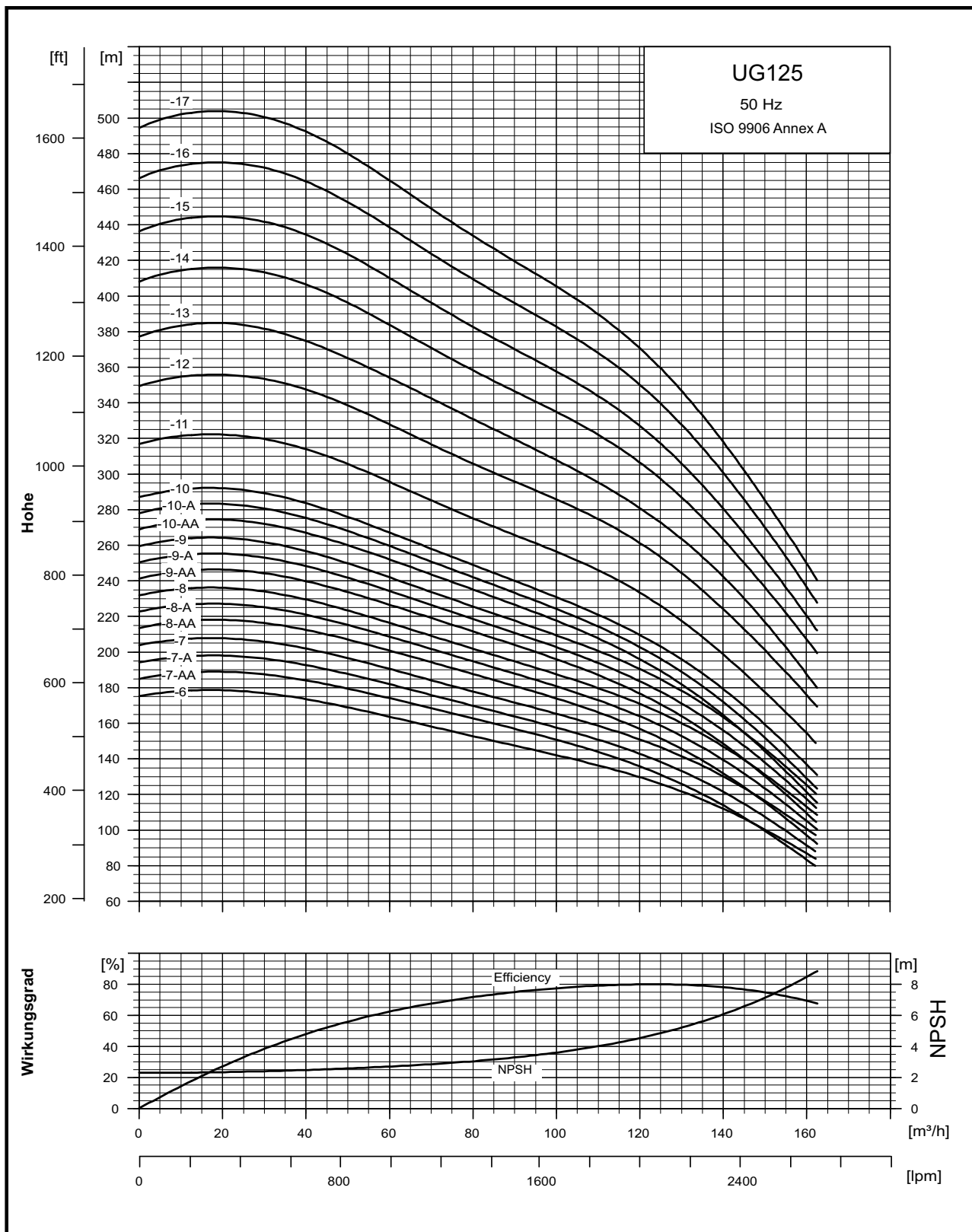

# UG125 - Technische Informationen

## Dimension und Gewicht

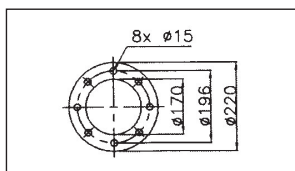
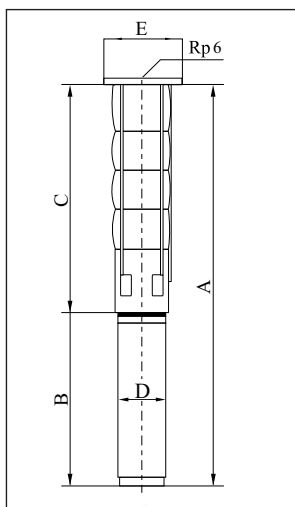

Pumpentyp	Motor		Dimensionen (mm)										Netto Gewicht (kg)
	Typ UGM.... (inch/HP)	Power (KW/HP)	6" Anschluss (RP,NPT)				6" Flansch				B	D	
			A	C	E*	E**	A	C	E*	E**			
UG125-1-A	UGM6/10	7.5/10	1226	652	211	218	1226	652	222	226	574	143	61
UG125-1	UGM6/15	11/15	1287	652	211	218	1287	652	222	226	635	143	70
UG125-2-AA	UGM6/17.5	13/17.5	1471	807	211	218	1471	807	222	226	664	143	83
UG125-2-A	UGM6/25	18.5/25	1561	807	211	218	1561	807	222	226	754	143	92
UG125-2	UGM6/30	22/30	1619	807	211	218	1619	807	222	226	812	143	98
UG125-3-AA	UGM6/30	22/30	1775	963	211	218	1775	963	222	226	812	143	108
UG125-3-A	UGM6/35	26/35	1837	963	211	218	1837	963	222	226	874	143	114
UG125-3	UGM6/40	30/40	1907	963	211	218	1907	963	222	226	944	143	122
UG125-4-AA	UGM8/50	37/50	2128	1118	211	218	2128	1118	223	226	1010	190	195
UG125-4-A	UGM8/50	37/50	2128	1118	211	218	2128	1118	223	226	1010	190	195
UG125-4	UGM8/50	37/50	2128	1118	213	218	2128	1118	223	226	1010	190	195
UG125-5-AA	UGM8/60	45/60	2333	1271	213	218	2333	1271	223	226	1062	190	221
UG125-5-A	UGM8/60	45/60	2333	1271	213	218	2333	1271	223	226	1062	190	221
UG125-5	UGM8/75	55/75	2439	1271	213	218	2439	1271	223	226	1168	190	245
UG125-6-AA	UGM8/75	55/75	2597	1429	213	218	2597	1429	223	226	1168	190	254
UG125-6-A	UGM8/75	55/75	2597	1429	213	218	2597	1429	223	226	1168	190	254
UG125-6	UGM8/90	67/90	2691	1429	218	227	2691	1429	229	232	1262	192	273
UG125-7-AA	UGM8/90	67/90	2847	1585	218	227	2847	1585	229	232	1262	192	283
UG125-7-A	UGM8/90	67/90	2847	1585	218	227	2847	1585	229	232	1262	192	283
UG125-7	UGM8/100	75/100	2909	1585	218	227	2909	1585	229	232	1324	192	300
UG125-8-AA	UGM8/100	75/100	3034	1710	218	227					1324	192	311
UG125-8-A	UGM8/100	75/100	3034	1710	218	227					1324	192	311
UG125-8	UGM8/100	75/100	3034	1710	218	227					1324	192	311
UG125-9-AA	UGM8/125	92/125	3365	1896	218	227					1469	192	353
UG125-9-A	UGM8/125	92/125	3365	1896	218	227					1469	192	353
UG125-9	UGM8/125	92/125	3365	1896	218	227					1469	192	353
UG125-10AA	UGM8/125	92/125	3520	2051	218	227					1469	192	363
UG125-10A	UGM8/125	92/125	3520	2051	218	227					1469	192	363
UG125-10	UGM8/125	92/125	3520	2051	218	227					1469	192	363
UG125-11	UGM8/150	110/150	3774	2207	218	227					1567	192	511
UG125-12	UGM10/200	147/200	4167	2492	227	247					1675	230	571
UG125-13	UGM10/200	147/200	4293	2618	227	247					1675	230	582
UG125-14	UGM10/200	147/200	4478	2803	227	247					1675	230	722
UG125-15	UGM10/200	147/200	4634	2959	227	247					1675	230	732
UG125-16	UGM10/250	185/250	4898	3114	227	247					1784	230	782
UG125-17	UGM10/250	185/250	5054	3270	227	247					1784	230	792

\* Maximum Durchmesser von Pumpe mit Motor und einem Kabel

\*\* Maximum Durchmesser von Pumpe mit Motor und 2 Kabeln

# UG125 - Leistungskurve

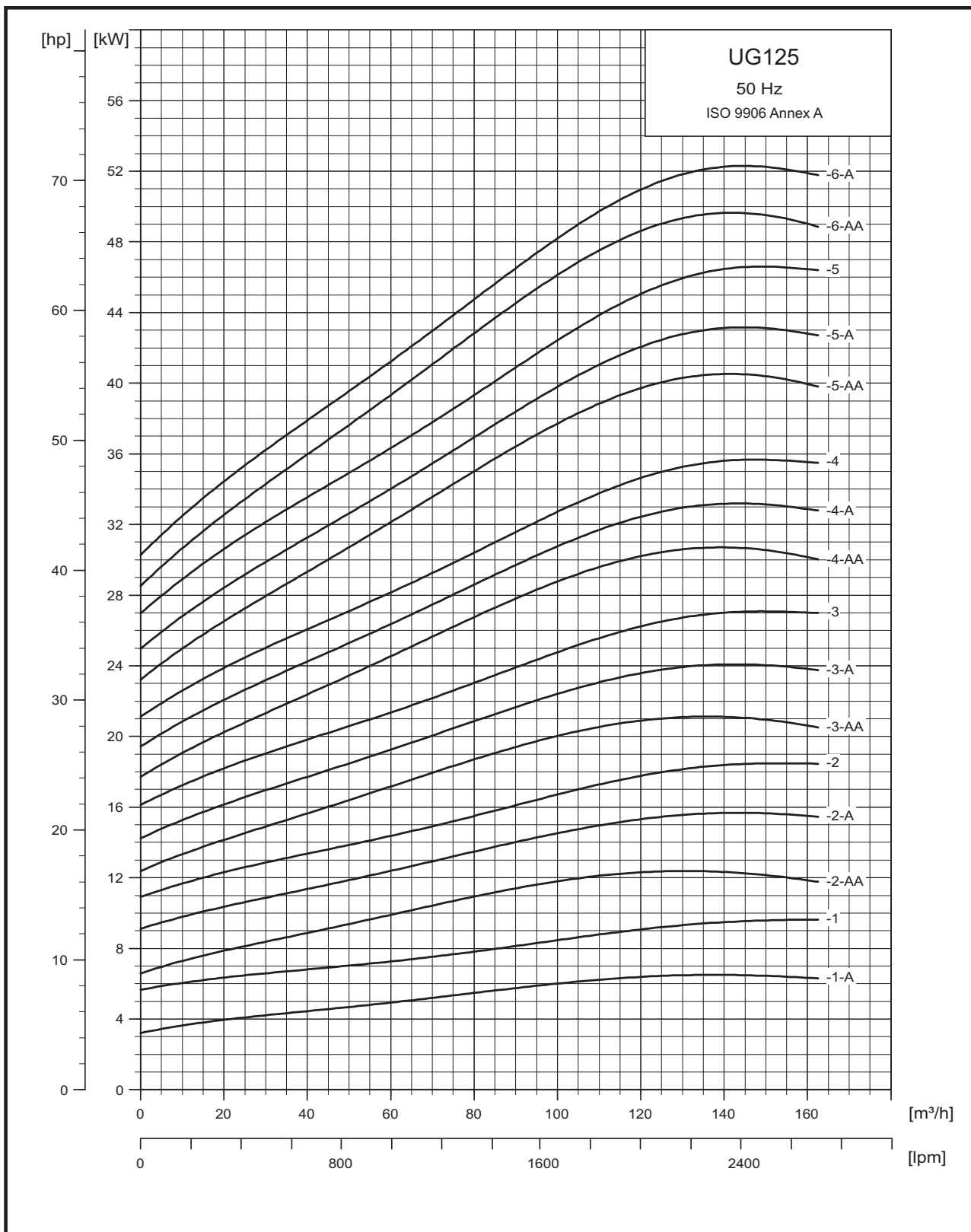

# UG125 - Leistungskurve

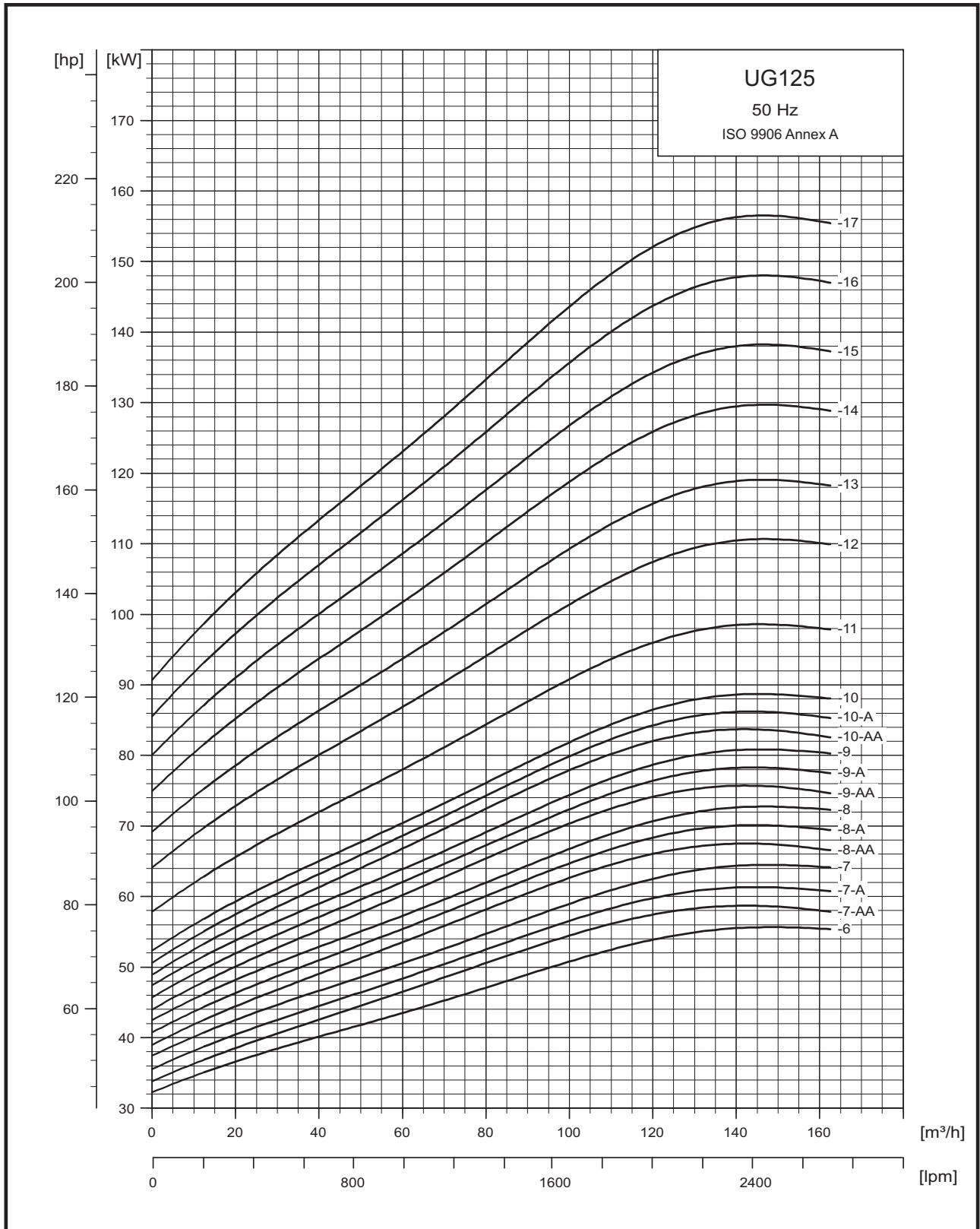

# UG160 - Kennlinien

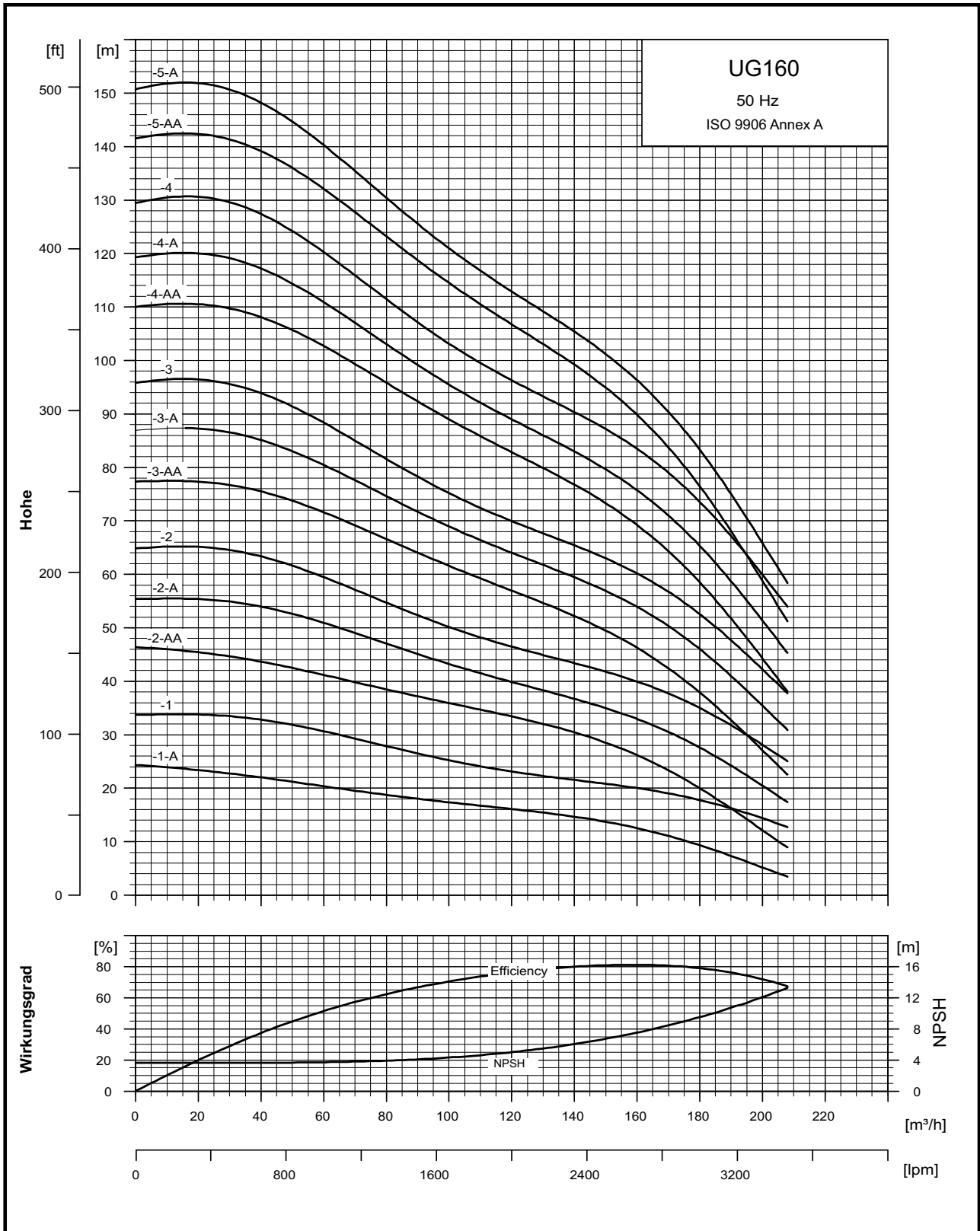

# UG160 - Kennlinien

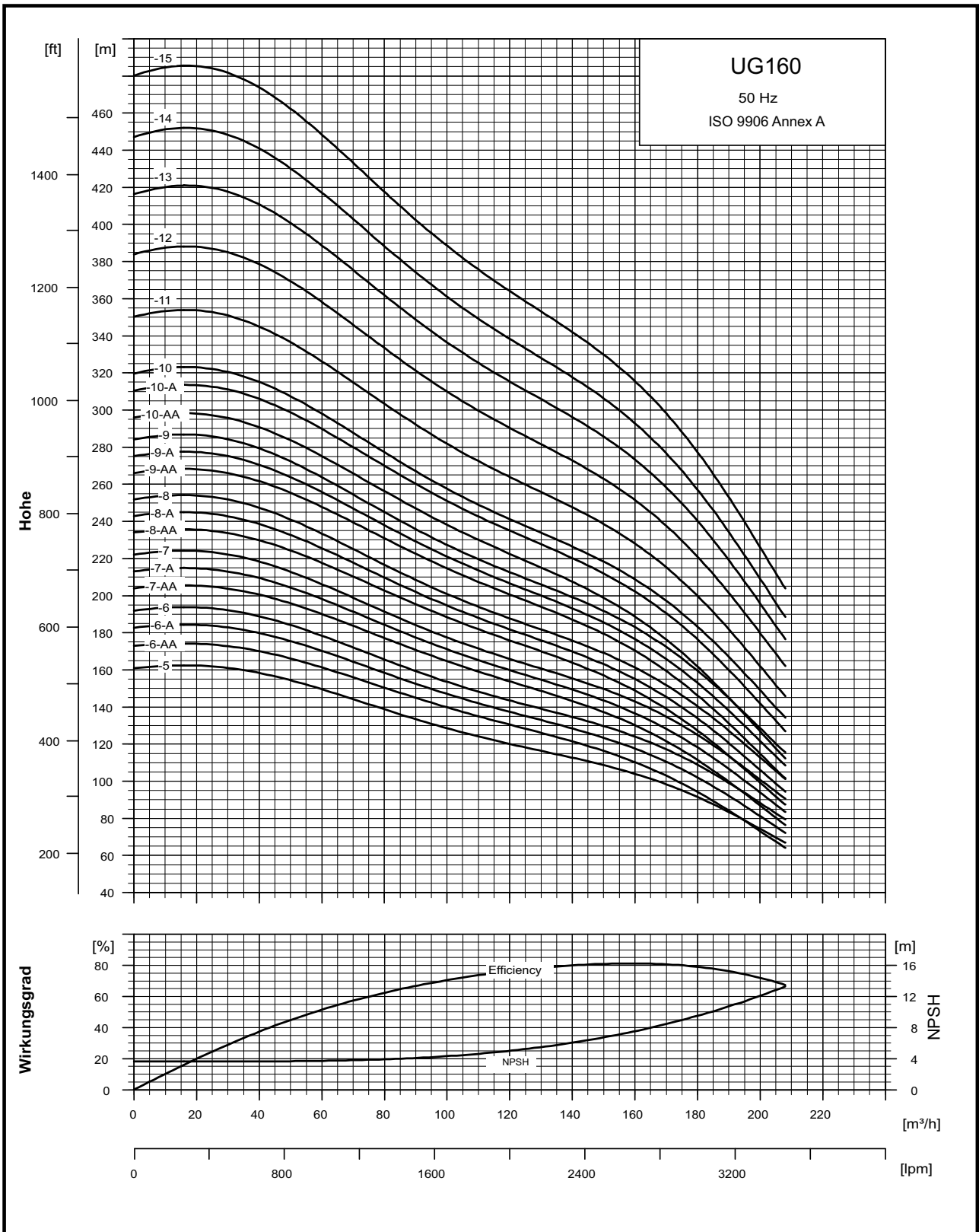

# UG160 - Technische Informationen

## Dimension und Gewicht

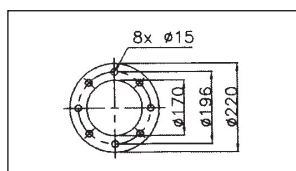
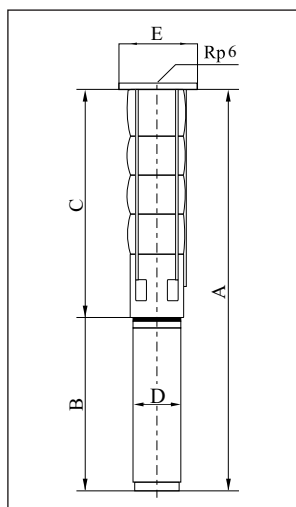

Pumpentyp	Motor		Dimensionen (mm)										Netto Gewicht (kg)
	Typ UGM... (inch/HP)	Power (KW/HP)	6" Anschluss (RP,NPT)				6" Flansch				B	D	
			A	C	E*	E**	A	C	E*	E**			
UG160-1-A	UGM6/12.5	9.2 / 12.5	1372	652	211	218	1372	652	222	226	720	143	67
UG160-1	UGM6/17.5	13 / 17.5	1316	652	211	218	1316	652	222	226	664	143	70
UG160-2-AA	UGM6/25	18.5 / 25	1561	807	211	218	1561	807	222	226	754	143	92
UG160-2-A	UGM6/30	22 / 30	1619	807	211	218	1619	807	222	226	812	143	98
UG160-2	UGM6/35	26 / 35	1681	807	211	218	1681	807	222	226	874	143	104
UG160-3-AA	UGM6/40	30 / 40	1907	963	211	218	1907	963	222	226	944	143	122
UG160-3-A	UGM8/50	37 / 50	1973	963	211	218	1973	963	222	226	1010	190	185
UG160-3	UGM8/50	37 / 50	1973	963	211	218	1973	963	222	226	1010	190	185
UG160-4-AA	UGM8/60	45 / 60	2180	1118	218	227	2180	1118	229	232	1062	190	211
UG160-4-A	UGM8/60	45 / 60	2180	1118	218	227	2180	1118	229	232	1062	190	211
UG160-4	UGM8/75	55 / 75	2286	1118	218	227	2286	1118	229	232	1168	190	234
UG160-5-AA	UGM8/75	55 / 75	2442	1274	218	227	2442	1274	229	232	1168	190	244
UG160-5-A	UGM8/75	55 / 75	2442	1274	218	227	2442	1274	229	232	1168	190	244
UG160-5	UGM8/90	67 / 90	2536	1274	218	227	2536	1274	229	232	1262	192	263
UG160-6-AA	UGM8/90	67 / 90	2691	1429	218	227	2691	1429	229	232	1262	192	273
UG160-6-A	UGM8/100	75 / 100	2753	1429	218	227	2753	1429	229	232	1324	192	290
UG160-6	UGM8/100	75 / 100	2753	1429	218	227	2753	1429	229	232	1324	192	290
UG160-7-AA	UGM8/100	75 / 100	2909	1585	218	227					1324	192	300
UG160-7-A	UGM8/125	92 / 125	3054	1585	218	227					1469	192	332
UG160-7	UGM8/125	92 / 125	3054	1585	218	227					1469	192	332
UG160-8-AA	UGM8/125	92 / 125	3209	1740	218	227					1469	192	343
UG160-8-A	UGM8/125	92 / 125	3209	1740	218	227					1469	192	343
UG160-8	UGM8/125	92 / 125	3209	1740	218	227					1469	192	343
UG160-9-AA	UGM10/150	110 / 150	3341	1896	218	227					1445	230	439
UG160-9-A	UGM10/150	110 / 150	3341	1896	218	227					1445	230	439
UG160-9	UGM10/150	110 / 150	3341	1896	218	227					1445	230	439
UG160-10-AA	UGM10/150	110 / 150	3496	2051	218	227					1445	230	449
UG160-10-A	UGM10/200	147 / 200	3856	2181	227	247					1675	230	451
UG160-10	UGM10/200	147 / 200	3856	2181	227	247					1675	230	451
UG160-11	UGM10/200	147 / 200	4012	2337	227	247					1675	230	561
UG160-12	UGM10/200	147 / 200	4167	2492	227	247					1675	230	636
UG160-13	UGM10/250	185 / 250	4432	2648	227	247					1784	230	752
UG160-14	UGM10/250	185 / 250	4587	2803	227	247					1784	230	762
UG160-15	UGM12/260	190 / 260	-	-	227	247					-	-	-

\* Maximum Durchmesser von Pumpe mit Motor und einem Kabel

\*\* Maximum Durchmesser von Pumpe mit Motor und 2 Kabeln

- Auf Anfrage

# UG160 - Leistungskurve

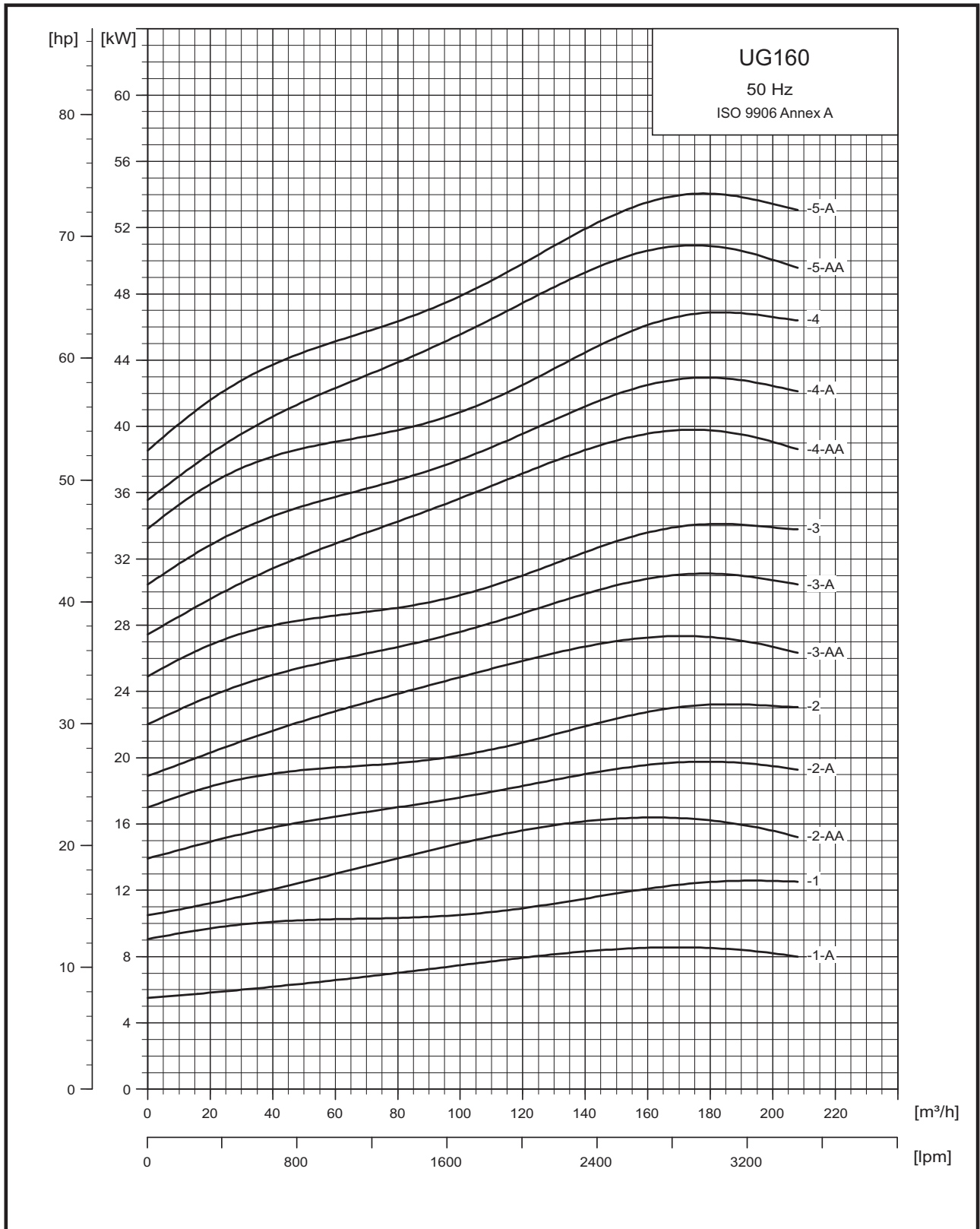



# UG160 - Leistungskurve

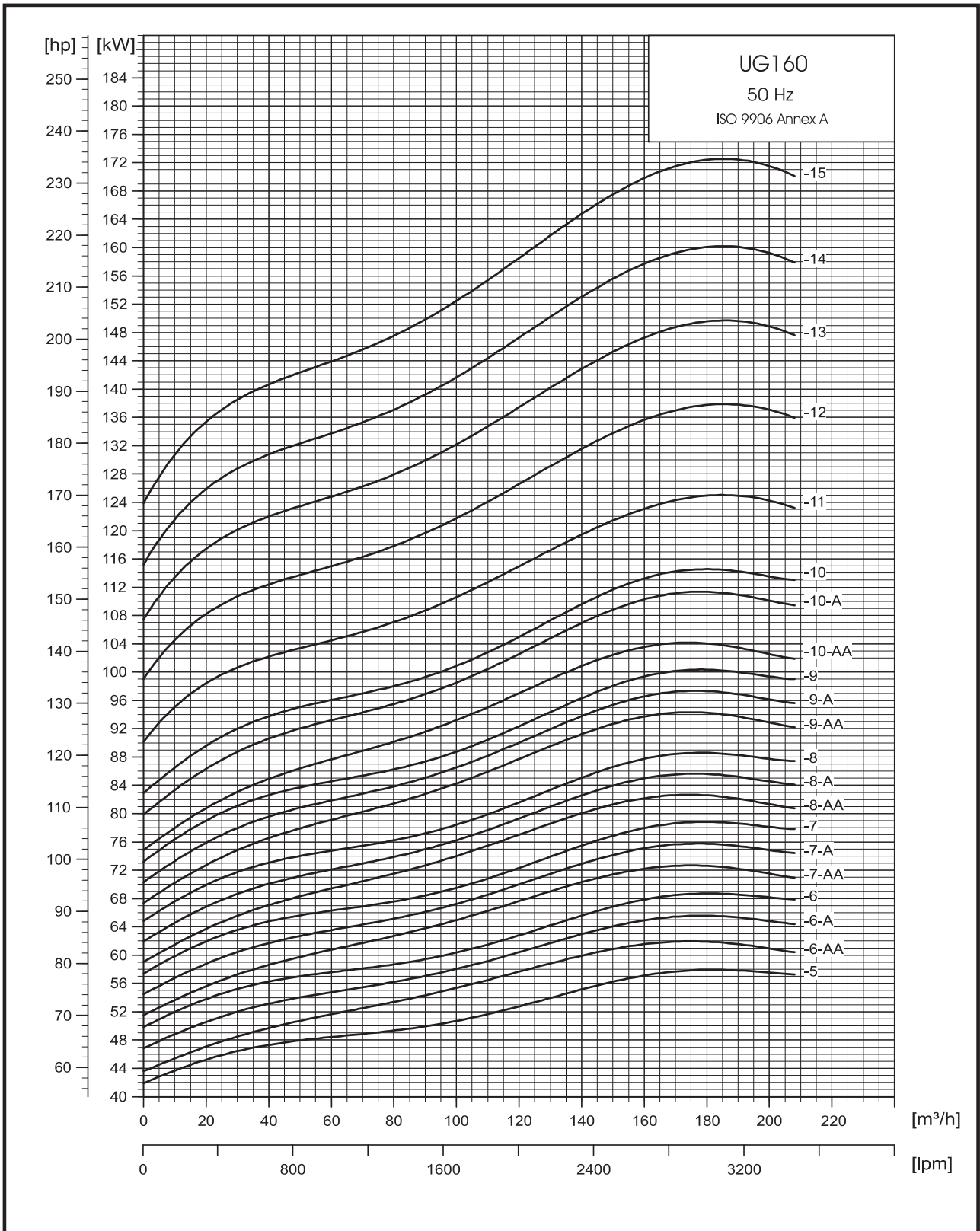

# UG215 - Kennlinien

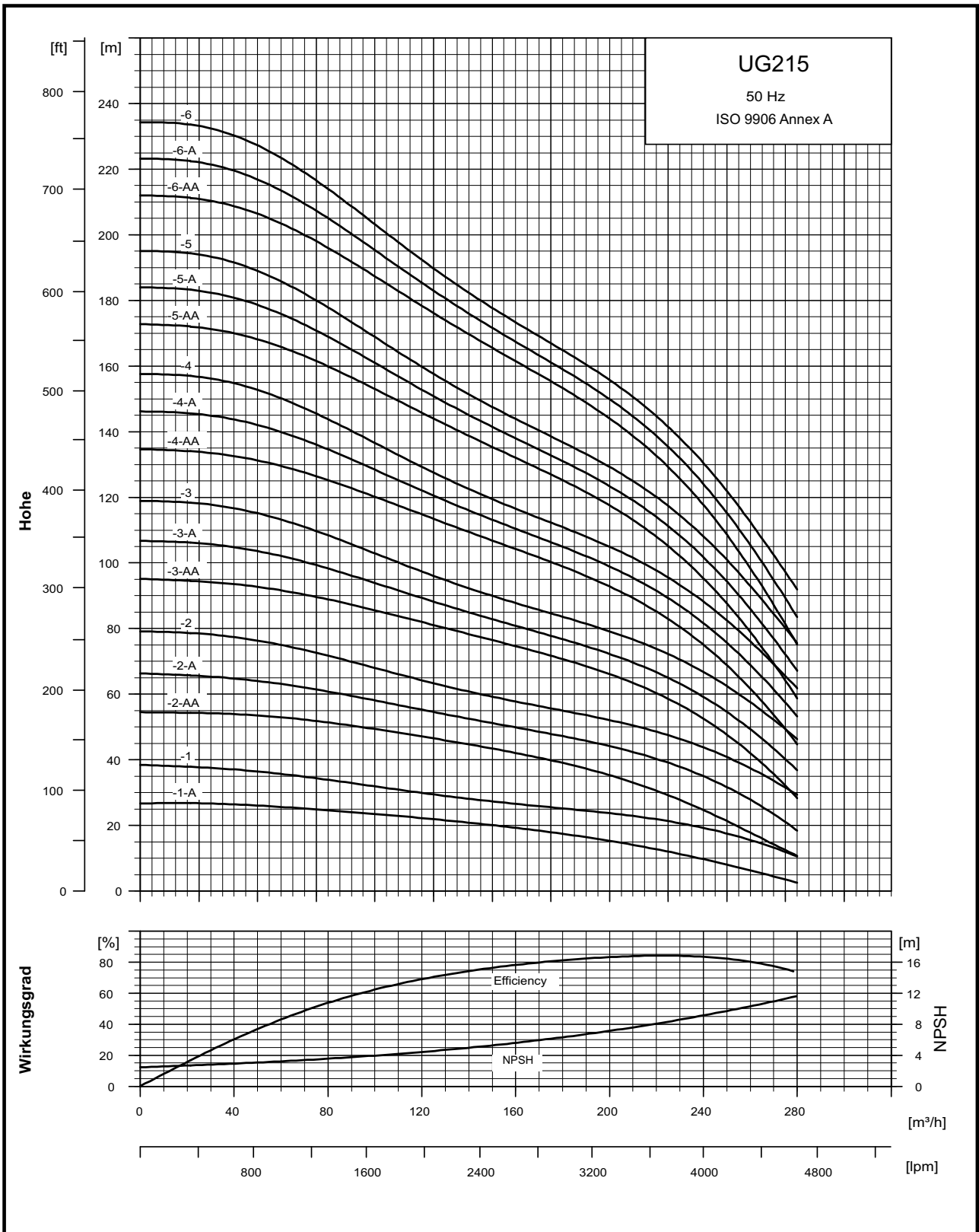

# UG215 - Kennlinien

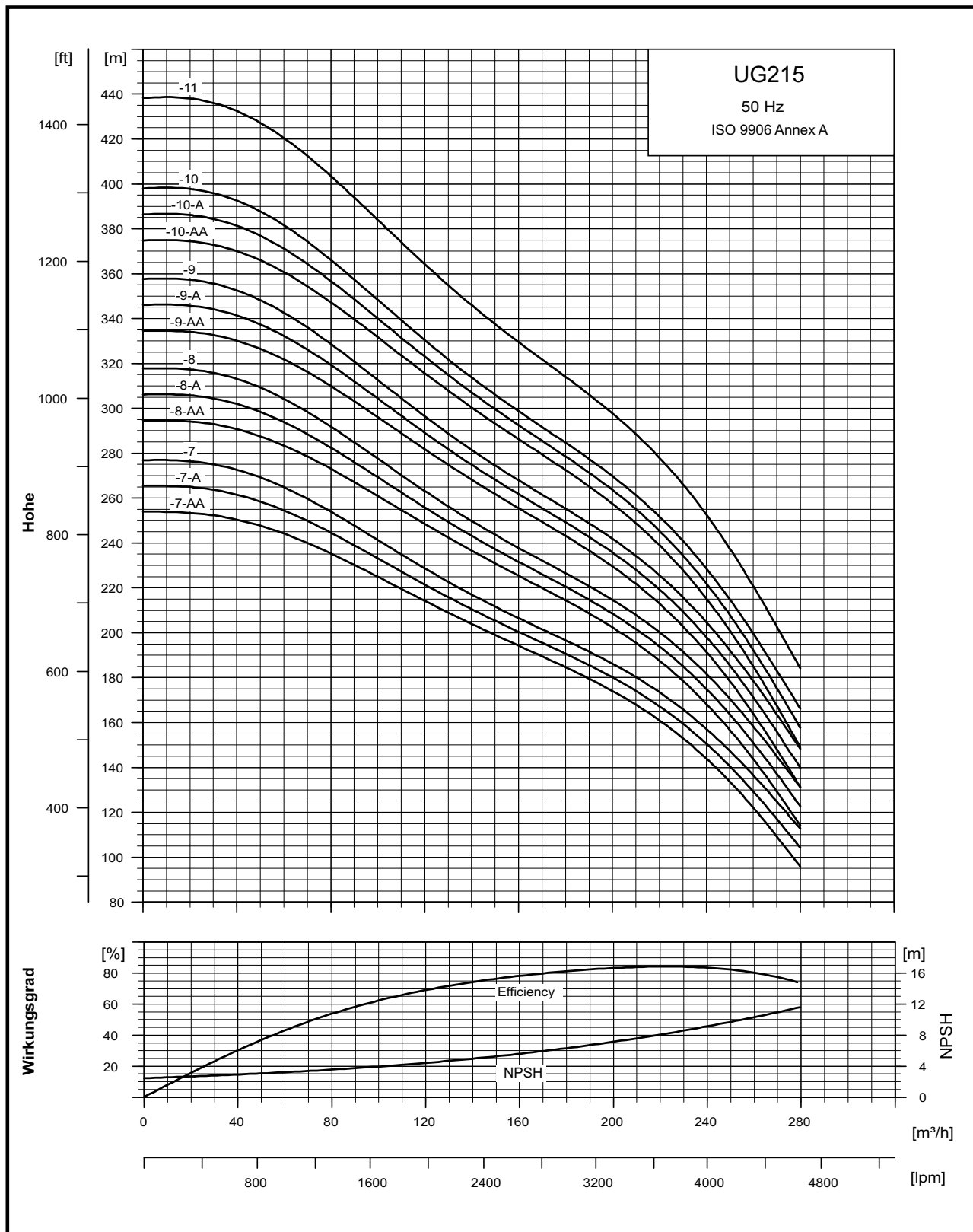

# UG215 - Technische Informationen

## Dimension und Gewicht

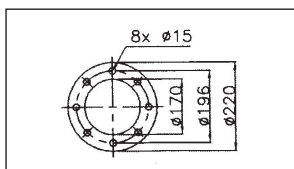
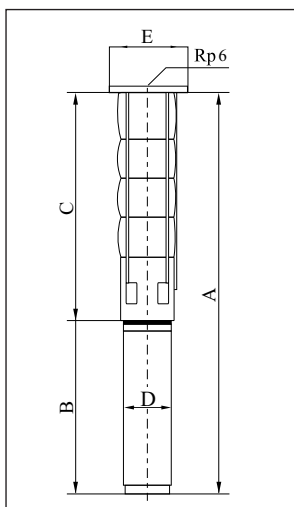

Pumpentyp	Motor		Dimensionen (mm)										Netto Gewicht (kg)
	Typ UGM.... (inch/HP)	Power (KW/HP)	6" Anschluss (RP,NPT)				6" Flansch				B	D	
			A	C	E*	E**	A	C	E*	E**			
UG215-1-A	UGM6/20	15 / 20	1470	772	237	241	1470	772	241	247	698	143	92
UG215-1	UGM6/25	18.5 / 25	1516	772	237	241	1516	772	241	247	744	143	97
UG215-2-AA	UGM6/40	30 / 40	1891	947	237	241	1891	947	241	247	944	143	142
UG215-2-A	UGM8/50	37 / 50	1957	947	237	241	1957	947	241	247	1010	190	205
UG215-2	UGM8/60	45 / 60	2009	947	237	241	2009	947	241	247	1062	190	221
UG215-3-AA	UGM8/75	55 / 75	2292	1124	237	241	2292	1124	241	247	1168	190	270
UG215-3-A	UGM8/75	55 / 75	2292	1124	237	241	2292	1124	241	247	1168	190	270
UG215-3	UGM8/90	67 / 90	2386	1124	237	241	2386	1124	241	247	1262	192	289
UG215-4-AA	UGM8/100	75 / 100	2624	1300	237	241	2624	1300	241	247	1324	192	331
UG215-4-A	UGM8/100	75 / 100	2624	1300	237	241	2624	1300	241	247	1324	192	331
UG215-4	UGM8/100	75 / 100	2624	1300	237	241	2624	1300	241	247	1324	192	331
UG215-5-AA	UGM8/125	92 / 125	2944	1475	237	241	2944	1475	241	247	1469	192	389
UG215-5-A	UGM8/125	92 / 125	2944	1475	237	241	2944	1475	241	247	1469	192	389
UG215-5	UGM8/125	92 / 125	2944	1475	237	241	2944	1475	241	247	1469	192	389
UG215-6-AA	UGM8/150	110 / 150	3218	1651	237	241	3218	1651	241	247	1567	192	414
UG215-6-A	UGM8/150	110 / 150	3218	1651	237	241	3218	1651	241	247	1567	192	414
UG215-6	UGM10/150	110 / 150	3096	1651	237	241	3096	1651	241	247	1445	230	552
UG215-7-AA	UGM10/200	147 / 200	3502	1827	262	274					1675	230	628
UG215-7-A	UGM10/200	147 / 200	3502	1827	262	274					1675	230	628
UG215-7	UGM10/200	147 / 200	3502	1827	262	274					1675	230	628
UG215-8-AA	UGM10/200	147 / 200	3679	2004	262	274					1675	230	783
UG215-8-A	UGM10/200	147 / 200	3679	2004	262	274					1675	230	783
UG215-8	UGM10/200	147 / 200	3679	2004	262	274					1675	230	783
UG215-9-AA	UGM10/250	185 / 250	3964	2180	262	274					1784	230	849
UG215-9-A	UGM10/250	185 / 250	3964	2180	262	274					1784	230	849
UG215-9	UGM10/250	185 / 250	3964	2180	262	274					1784	230	849
UG215-10-AA	UGM12/260	190 / 260	-	-	-	-					-	-	-
UG215-10-A	UGM12/260	190 / 260	-	-	-	-					-	-	-
UG215-10	UGM12/260	190 / 260	-	-	-	-					-	-	-
UG215-11	UGM12/300	220 / 300	-	-	-	-					-	-	-

\* Maximum Durchmesser von Pumpe mit Motor und einem Kabel

\*\* Maximum Durchmesser von Pumpe mit Motor und 2 Kabeln

- Auf Anfrage

# UG215 - Leistungskurve

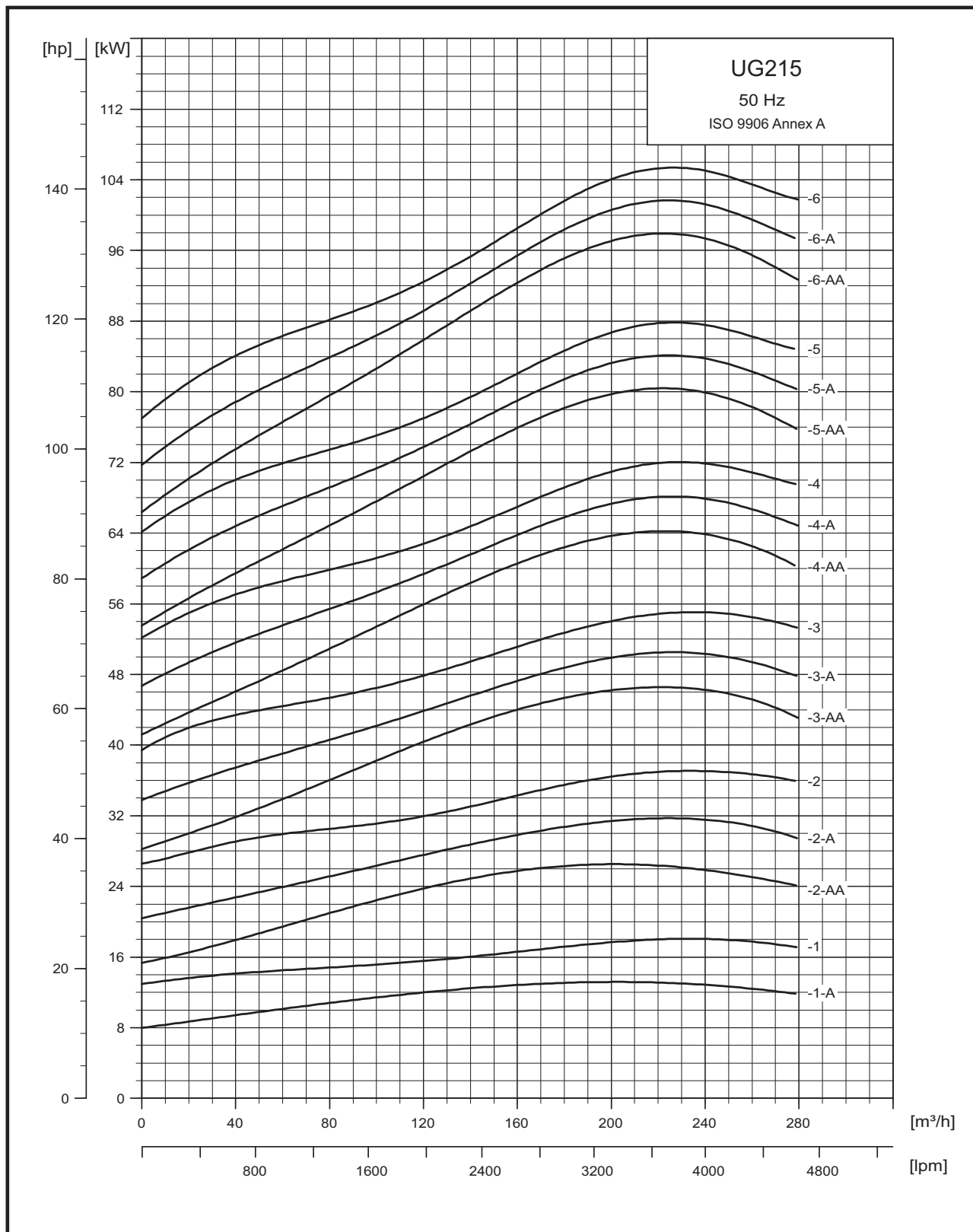

# UG215 - Leistungskurve

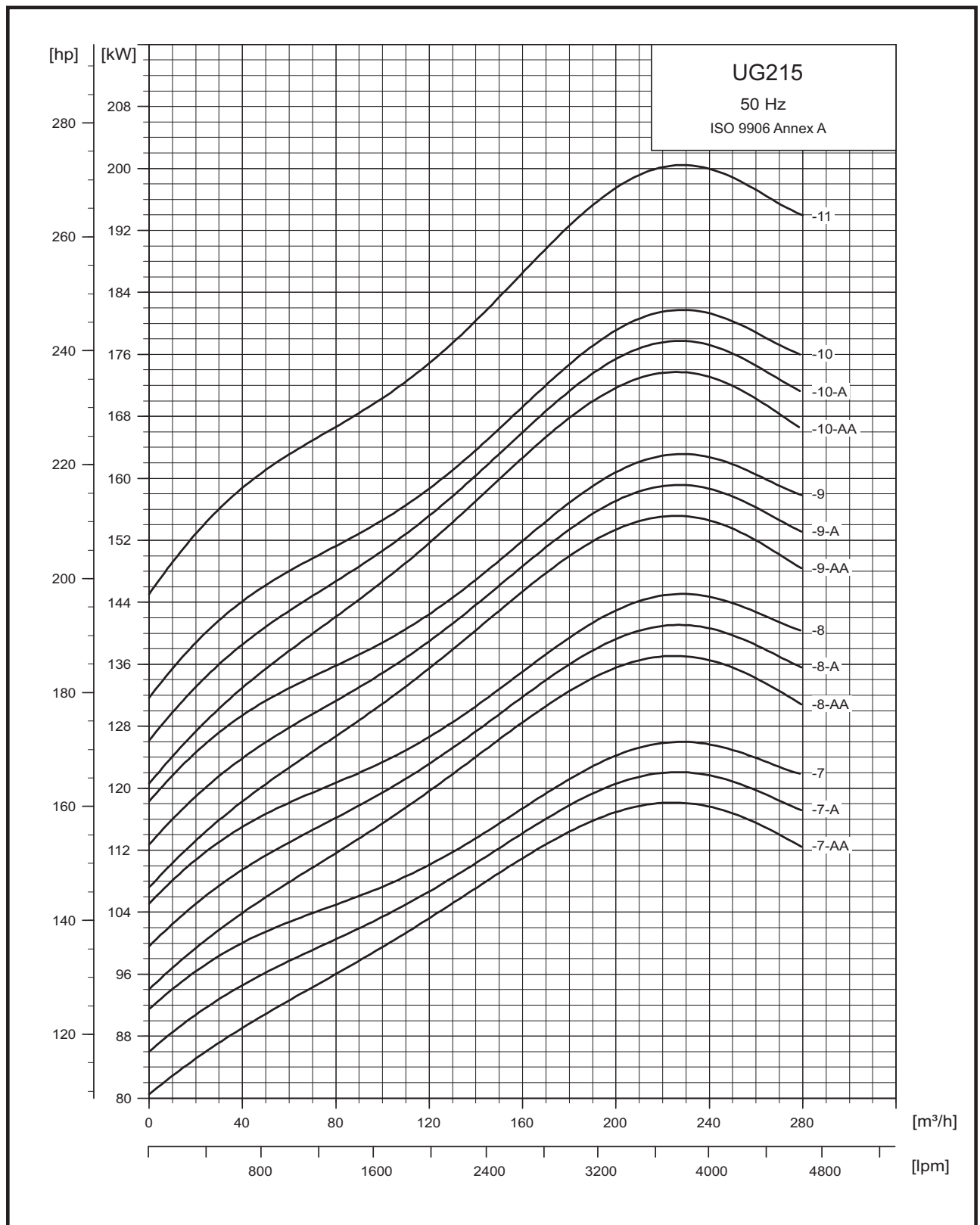

# Druckverluste in geraden Rohren

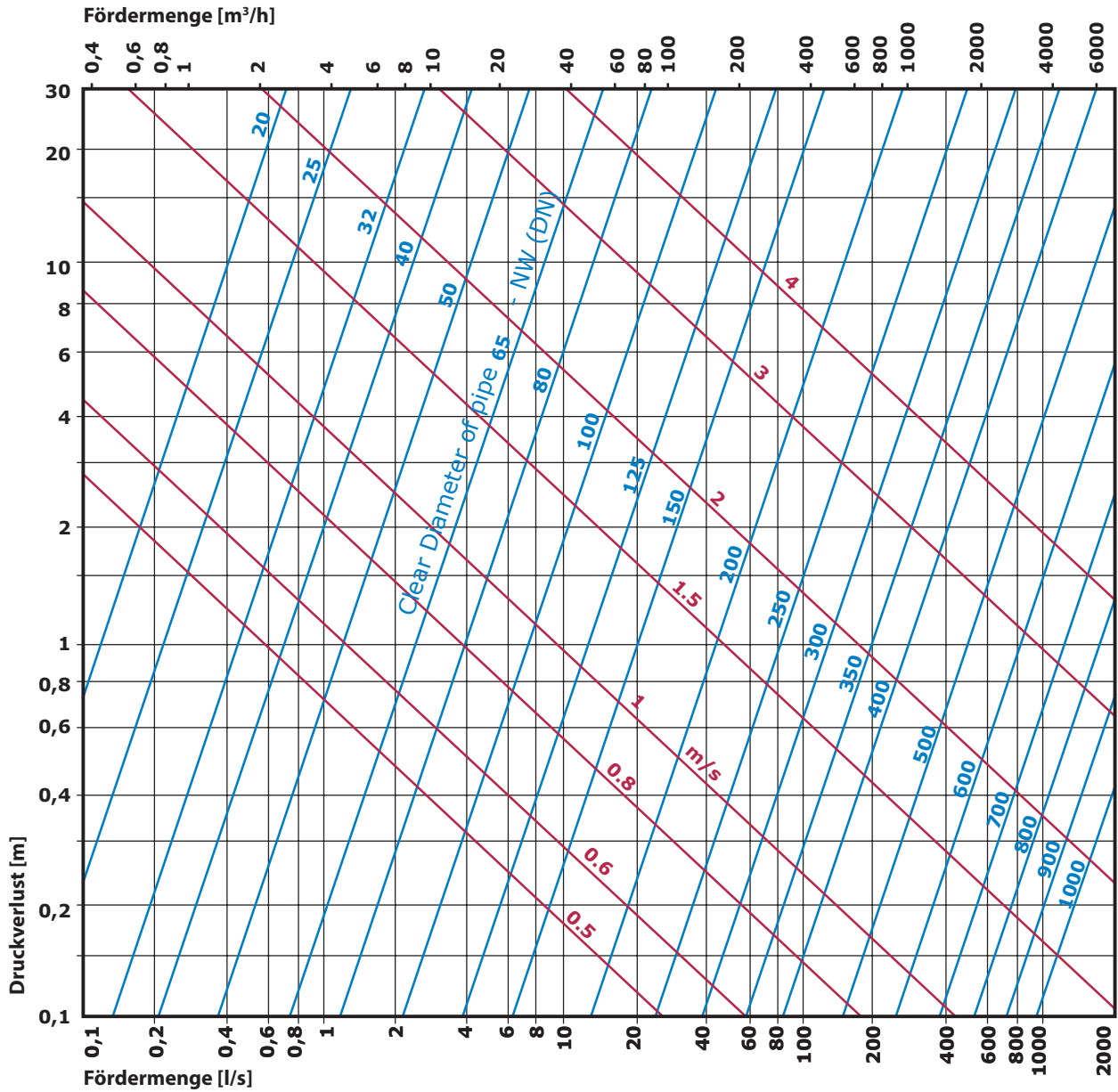

## Druckverlust in Metern für 100 m Druckleitung in GG – Grauguss

Der Druckverlust für:

Neu gerollte Stahlrohre:	0.8 Mal
Neue Plastikrohre:	0.8 Mal
Alte, rostige Graugussrohre:	1.25 Mal
Rohre mit Verkrustungen:	1.7 Mal

# Druckverluste in geraden Röhren

Die obere Zahl zeigt die Geschwindigkeit von Wasser in m/sek.  
Die untere Zahl zeigt die Höhe in Metern pro 100 m gerader Druckleitung.

Quantity of Water			Head Losses In Ordinary Water Pipes											
m <sup>3</sup> /h	Litres/min.	Litres/sec.	Nominal Pipe Diameter in Inches and Internal Diameter in (mm)											
			1/2"	3/4"	1	1 1/4"	1 1/2	2"	2 1/2"	3"	3 1/2"	4"	5"	6"
			15.75	21.25	27.00	35.75	41.25	52.50	68.00	80.25	92.50	105.0	130.0	155.5
0.6	10	0.16	0.855 9,910	0.470 2,407	0.292 0,784									
0.9	15	0.25	1.282 20,11	0.705 4,862	0.438 1,570	0.249 0,416								
1.2	20	0.33	1.710 33,53	0.940 8,035	0.584 2,588	0.331 0,677	0.249 0,346							
1.5	25	0.42	2.138 49,93	1.174 11,91	0.730 3,834	0.415 1,004	0.312 0,510							
1.8	30	0.50	2.565 69,34	1.409 16,50	0.876 5,277	0.498 1,379	0.374 0,700	0.231 0,223						
2.1	35	0.58	2.993 91,54	1.644 21,75	1.022 6,949	0.581 1,811	0.436 0,914	0.269 0,291						
2.4	40	0.67		1.879 27,66	1.168 8,820	0.664 2,290	0.499 1,160	0.308 0,368						
3.0	50	0.83		2.349 41,40	1.460 13,14	0.830 3,403	0.623 1,719	0.385 0,544	0.229 0,159					
3.6	60	1.00		2.819 57,74	1.751 18,28	0.996 4,718	0.748 2,375	0.462 0,751	0.275 0,218					
4.2	70	1.12		3.288 76,49	2.043 24,18	1.162 6,231	0.873 3,132	0.539 0,988	0.321 0,287	0.231 0,131				
4.8	80	1.33			2.335 30,87	1.328 7,940	0.997 3,988	0.616 1,254	0.367 0,363	0.263 0,164				
5.4	90	1.50			2.627 38,30	1.494 9,828	1.122 4,927	0.693 1,551	0.413 0,449	0.269 0,203				
6.0	100	1.67			2.919 46,49	1.660 11,90	1.247 5,972	0.770 1,875	0.459 0,542	0.329 0,244	0.248 0,124			
7.5	125	2.08			3.649 70,41	2.075 17,93	1.558 8,967	0.962 2,802	0.574 0,809	0.412 0,365	0.310 0,185	0.241 0,101		
9.0	150	2.50			2.490	1.870	1.154	0.668	0.494	0.372	0.289			
10.5	175	2.92			2.904	2.182	1.347	0.803	0.576	0.434	0.337			
12	200	3.33			3.319	2.493	1.539	0.918	0.659	0.496	0.385	0.251		
15	250	4.17			4.149	3.117	1.924	1.147	0.823	0.620	0.481	0.314		
18	300	5.00				3.740	2.309	1.377	0.988	0.744	0.577	0.377	0.263	
24	400	6.67				4.987	3.078	1.836	1.317	0.992	0.770	0.502	0.351	
30	500	8.33					3.848	2.295	1.647	1.240	0.962	0.628	0.439	
36	600	10.0						46.18	2.753	1.976	1.488	1.155	0.753	0.526
42	700	11.7							3.212	2.306	1.736	1.347	0.879	0.614
48	800	13.3							3.671	2.635	1.984	1.540	1.005	0.702
54	900	15.0							4.130	2.964	2.232	1.732	1.130	0.790
60	1000	16.7							4.589	3.294	2.480	1.925	1.256	0.877
75	1250	20.8								4.117	3.100	2.406	1.570	1.097
90	1500	25.0								4.941	3.720	2.887	1.883	1.316
105	1750	29.2									4.340	3.368	1.883	1.535
120	2000	33.3									4.960	3.850	2.197	1.754
150	2500	41.7										4.812	2.511	2.193
180	3000	50.0											2.511	3.139
240	4000	66.7												3.139
300	5000	83.3												3.139
90°C bends slide valves			1.0	1.0	1.1	1.2	1.3	1.4	1.5	1.6	1.6	1.6	1.7	2.5
T-pieces, non-return valves			4.0	4.0	4.0	5.0	5.0	5.0	6.0	6.0	6.0	6.0	7.0	9.0

Die Tabelle ist berechnet H. Lang neuer Berechnung  
a= 0.02 und mit einer Wassertemperatur von 10°C.

Der Druckverlust in Bögen, Schiebern, T-Stücken und Rückschlagklappen ist gleich dem Metern von gerader Strecke welche in den letzten 2 Zeilen der Tabelle ersichtlich sind. Um den Druckverlust in Fussventilen zu berechnen, können Sie das T-Stück mal 2 rechnen.



# Druckverluste in geraden Plastikrohren

Die obere Zahl zeigt die Geschwindigkeit von Wasser in m/sek.  
Die untere Zahl zeigt die Höhe in Metern pro 100 m gerader Druckleitung.

Quantity of Water			PELM/PEH PN 10													
m <sup>3</sup> /h	Litres/min.	Litres/sec.	PELM				PEH									
			25 20.4	32 26.2	40 32.6	50 40.8	63 51.4	75 73.6	90 73.6	110 90.0	125 102.2	140 11406	160 130.8	180 147.2		
0.6	10	0.16	0.49 1.8	0.30 0.66	0.19 0.27	0.12 0.085										
0.9	15	0.25	0.76 4.0	0.46 1.14	0.3 0.6	0.19 0.18	0.12 0.63									
1.2	20	0.33	1.0 6.4	0.61 2.2	0.39 0.9	0.25 0.28	0.16 0.11									
1.5	25	0.42	1.3 10.0	0.78 3.5	0.5 1.4	0.32 0.43	0.2 0.17	0.14 0.074								
1.8	30	0.50	1.53 13.0	0.93 4.6	0.6 1.9	0.38 0.57	0.24 0.22	0.17 0.092								
2.1	35	0.58	1.77 16.0	1.08 6.0	0.69 2.0	0.44 0.70	0.28 0.27	0.2 0.12								
2.4	40	0.67	2.05 22.0	1.24 7.5	0.80 3.3	0.51 0.93	0.32 0.35	0.23 0.16	0.16 0.063							
3.0	50	0.83	2.54 37.0	1.54 11.0	0.99 4.8	0.63 1.40	0.4 0.50	0.28 0.22	0.2 0.09							
3.6	60	1.00	3.06 43.0	1.85 15.0	1.2 6.5	0.76 1.90	0.48 0.70	0.34 0.32	0.24 0.13	0.16 0.050						
4.2	70	1.12	3.43 50.0	2.08 18.0	1.34 8.0	0.86 2.50	0.54 0.83	0.38 0.38	0.26 0.17	0.18 0.068						
4.8	80	1.33		2.47 25.0	1.59 10.5	1.02 3.00	0.64 1.20	0.45 0.50	0.31 0.22	0.2 0.084						
5.4	90	1.50		2.78 30.0	1.8 12.0	1.15 3.50	0.72 1.30	0.51 0.57	0.35 0.26	0.24 0.092	0.18 0.05					
6.0	100	1.67		3.1 39.0	2.0 16.0	1.28 4.6	0.8 1.80	0.56 0.73	0.39 0.30	0.26 0.12	0.2 0.07					
7.5	125	2.08		3.86 50.0	2.49 24.0	1.59 6.6	1.00 2.50	0.70 1.10	0.49 0.50	0.33 0.18	0.25 1.10	0.20 0.055				
9.0	150	2.50			3.00 33.0	1.91 8.6	1.20 3.5	0.84 1.40	0.59 0.63	0.39 0.24	0.30 0.13	0.24 0.075				
10.5	175	2.92			3.5 38.0	2.23 11.0	1.41 4.3	0.99 1.80	0.69 0.78	0.46 0.30	0.36 0.18	0.28 0.09				
12	200	3.33			3.99 50.0	2.55 14.0	1.60 5.5	1.12 2.40	0.78 1.0	0.52 0.40	0.41 0.22	0.32 0.12	0.25 0.065			
15	250	4.17				3.19 21.0	2.01 8.0	1.41 3.70	0.98 1.50	0.66 0.57	0.51 0.34	0.40 0.18	0.31 0.105	0.25 0.06		
18	300	5.00				3.82 28.0	2.41 10.5	1.69 4.60	1.18 1.95	0.78 0.77	0.61 0.45	0.48 0.25	0.37 0.13	0.29 0.085		
24	400	6.67				3.21 19.0	2.25 8.0	1.57 3.60	1.05 1.40	0.81 0.78	0.65 0.44	0.50 0.23	0.39 0.15			
30	500	8.33				4.01 28.0	2.81 11.5	1.96 5.0	1.0 2.0	1.02 1.20	0.81 0.63	0.62 0.33	0.49 0.21			
36	600	10.0				4.82 37.0	3.38 15.0	2.35 6.6	1.57 2.60	1.22 1.50	0.97 0.82	0.74 0.45	0.59 0.28			
42	700	11.7				5.64 47.0	3.95 24.0	2.75 8.0	1.84 3.50	1.43 1.90	1.13 1.10	0.87 0.60	0.69 0.40			
48	800	13.3					4.49 26.0	3.13 11.0	2.09 4.5	1.62 2.60	1.29 1.40	0.99 0.81	0.78 0.48			
54	900	15.0					5.07 33.0	3.53 13.5	2.36 5.5	1.83 3.20	1.45 1.70	1.12 0.95	0.08 0.58			
60	1000	16.7					5.64 40.0	3.93 16.0	2.63 6.7	2.04 3.90	1.62 2.2	1.24 1.2	0.96 0.75			
75	1250	20.8						4.89 25.0	3.27 9.0	2.54 5.0	2.02 3.0	1.55 1.6	1.22 0.95			
90	1500	25.0						5.88 33.0	3.93 13.0	3.05 8.0	2.42 4.1	1.86 2.3	1.47 1.40			
105	1750	29.2						6.86 44.0	4.59 17.5	3.56 9.7	2.83 5.7	2.17 3.2	1.72 1.9			
120	2000	33.3							5.23 23.0	4.06 13.0	3.23 7.0	2.48 4.0	1.96 2.4			
150	2500	41.7							6.55 34.0	5.08 18.0	4.04 10.5	3.10 6.0	2.45 3.5			
180	3000	50.0							7.86 45.0	6.1 27.0	4.85 14.0	3.72 7.6	2.94 7.5			
240	4000	66.7								8.13 43.0	6.47 24.0	4.96 13.0	3.92 7.5			
300	5000	83.3									8.08 33.0	6.2 18.0	4.89 11.0			

Die Tabelle basiert auf Nomogramm.  
Härte: K=0,01mm  
Wassertemperatur: t= 10°C

# Tabellen zur Kabelauswahl

D.O.L. Direktanlauf 400V – mehr adriges Kabel

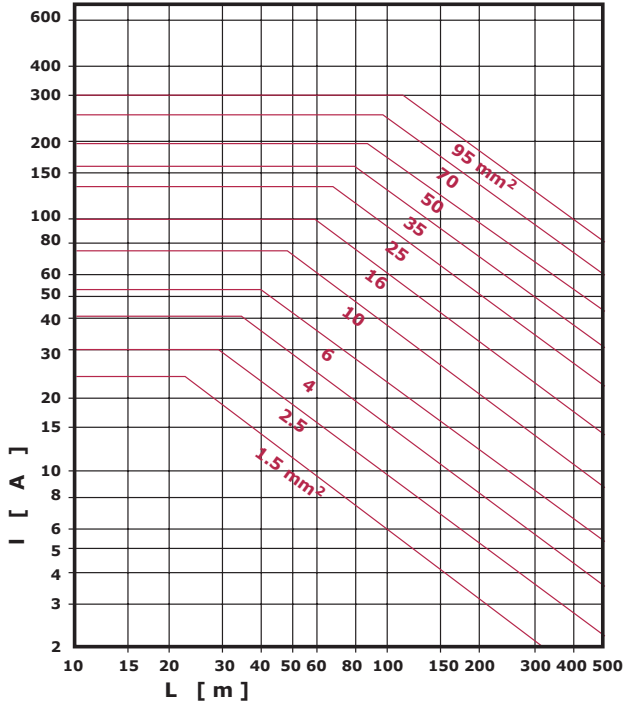

Stern Dreieck Anlauf 400V – mehr adriges Kabel

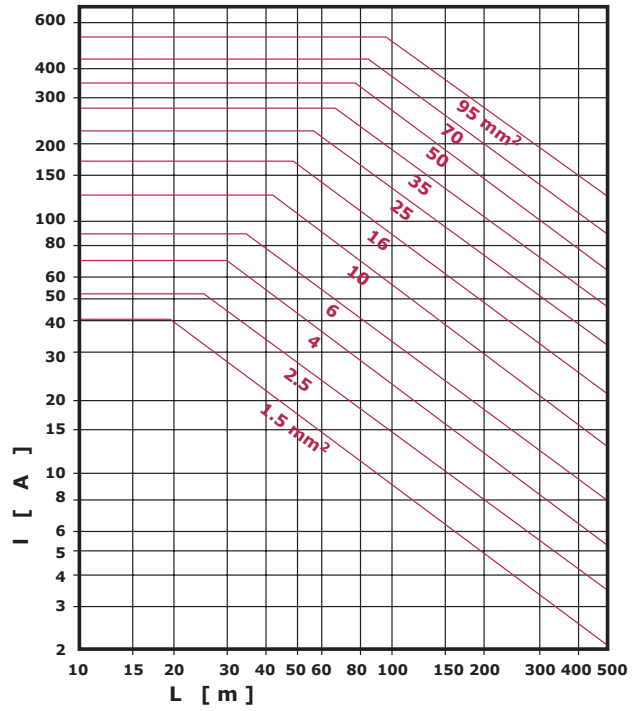

D.O.L. Anlauf 230V – mehr adriges Kabel

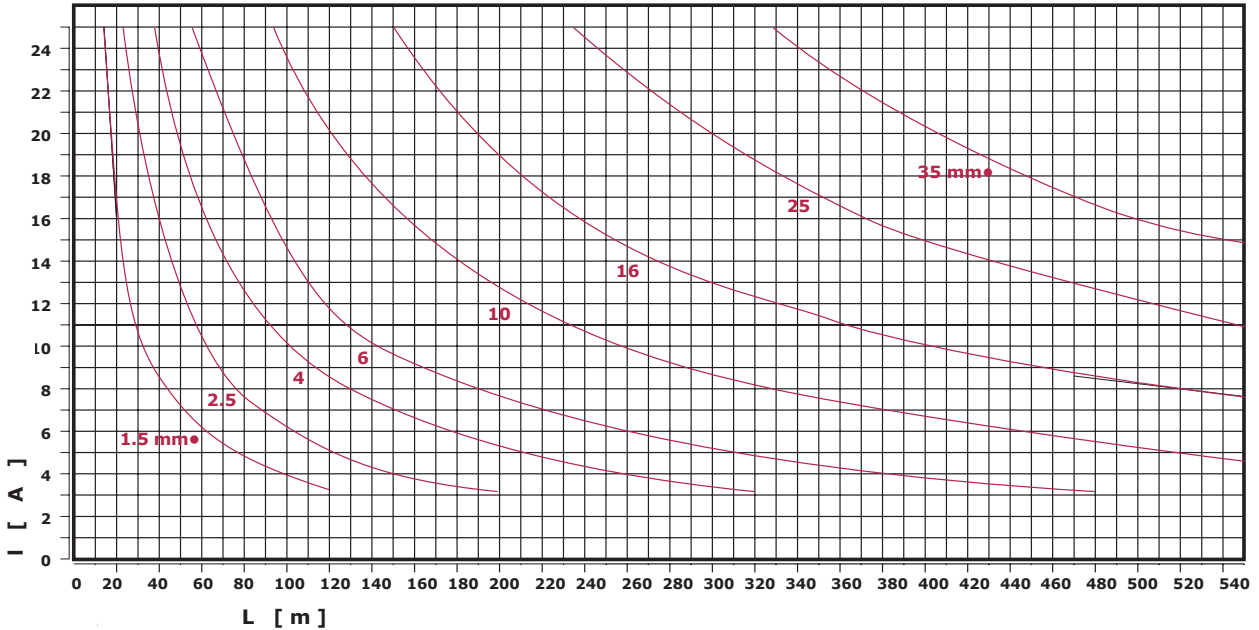

# Kabelgrößen

Stern Dreieck Betrieb (Y/D) maximale Kabellänge (m)											
Motorgrosse (HP)	Kabelgrösse (mm <sup>2</sup> )										
	3x1.5	3x2.5	3x4	3x6	3x10	3x16	3x25	3x35	3x50	3x70	3x95
5.5	97	161	258	388	646	1033	1615	2261	3230	4521	6139
7.5	72	121	193	290	483	773	1207	1690	2415	3381	4588
10	57	96	153	230	383	613	958	1342	1916	2683	3641
12.5	47	78	125	188	313	501	783	1096	1565	2191	2974
15	41	68	109	163	271	434	678	949	1356	1899	2577
17.5	34	57	92	138	230	367	574	803	1148	1607	2181
20	29	49	79	118	196	314	491	688	982	1375	1867
25		40	64	96	159	255	398	558	797	1115	1514
30			54	81	136	217	339	475	678	949	1288
35			46	68	114	182	285	399	570	798	1083
40				60	101	161	252	352	503	705	956
50					84	134	209	293	418	585	794
60					69	110	172	241	344	481	653
70					59	95	149	208	297	416	565
75						90	141	197	281	394	534
80						82	129	180	258	361	490
90						74	115	162	231	323	439
100							103	144	206	289	392
110							95	134	191	267	363
125								118	168	235	319
150								101	144	201	273
175									123	172	233
200										152	207
210										152	196

D.O.L. Direktanlauf maximale Kabellänge (m)											
Motorgrosse (HP)	Kabelgrösse (mm <sup>2</sup> )										
	3x1.5	3x2.5	3x4	3x6	3x10	3x16	3x25	3x35	3x50	3x70	3x95
5.5	65	108	172	258	431	689	1077	1507	2153	3014	4091
7.5	48	80	129	193	322	515	805	1127	1610	2254	3059
10	38	64	102	153	256	409	639	894	1278	1789	2428
12.5		52	83	125	209	334	522	730	1043	1461	1982
15		45	72	109	181	289	452	633	904	1266	1718
17.5			61	92	153	245	383	536	765	1071	1454
20			52	79	131	210	327	458	655	917	1244
25					106	170	266	372	531	744	1009
30					90	145	226	316	452	633	859
35					76	122	190	266	380	532	722
40					67	107	168	235	336	470	638
50						89	139	195	279	390	529
60							115	160	229	321	435
70								139	198	278	377
75								131	187	262	356
80								120	172	241	326
90									154	215	292
100									137	192	261
110									127	178	242
125										157	213
150											182
175											155
200											
210											

